

Surname		Other Names	
Centre Number		Candidate Number	
Candidate Signature			

For Examiner's use

General Certificate of Education
June 2007
Advanced Subsidiary Examination



PHYSICS (SPECIFICATION B)
Unit 3 Practical

PHB3

Wednesday 16 May 2007 1.30 pm to 3.30 pm

<p>For this paper you must have:</p> <ul style="list-style-type: none"> • a calculator • A4 graph paper • a ruler.
--

For Examiner's Use			
Question	Mark	Question	Mark
1			
2			
3			
Total (Column 1) →			
Total (Column 2) →			
TOTAL			
Examiner's Initials			

Time allowed: 2 hours

Instructions

- Use blue or black ink or ball-point pen.
- Fill in the boxes at the top of this page.
- Answer **all** questions.
- Answer the questions in the spaces provided. A separate sheet of graph paper is required for Question 3. Attach your graph to this book before handing it to the invigilator at the end of the examination.
- Show all your working.
- Do all rough work in this book. Cross through any work you do not want to be marked.

Information

- The maximum mark for this paper is 78.
- Four of these marks will be awarded for using good English, organising information clearly and using specialist vocabulary where appropriate.
- The marks for questions are shown in brackets.
- You are expected to use a calculator where appropriate.
- Questions 1(e) and 2(f) should be answered in continuous prose. In these questions you may be marked on your ability to use good English, to organise information clearly and to use specialist vocabulary where appropriate.

Advice

- You are allowed 30 minutes for each of Questions 1 and 2, and one hour for Question 3.
- Before commencing the first part of any question, read the question through completely.

Answer **all** questions.

You are allowed 30 minutes for this question.

- 1 Granular solids, such as table salt and sugar, exhibit fluid properties when they are caused to flow through tubes and pipes. In this question you are going to investigate the flow of granular solids through a tube and consider the physical factors which affect the rate of flow.

The apparatus is shown in **Figure 1**.

Figure 1

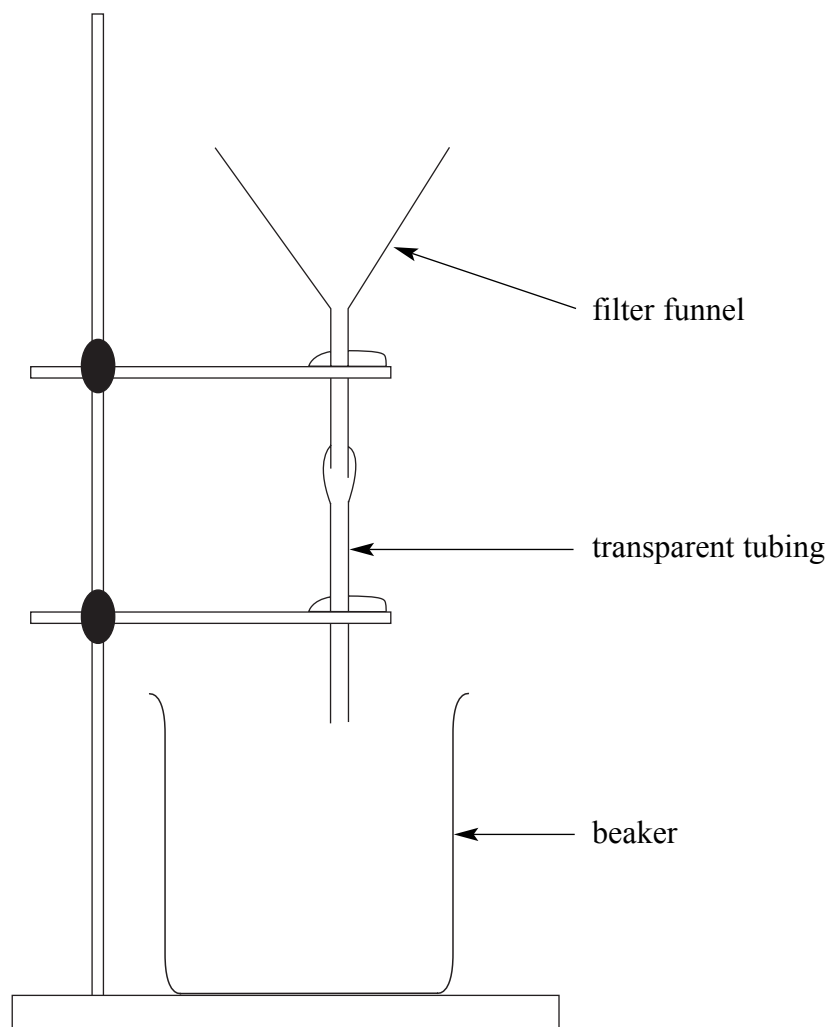

- (a) You are going to measure the time taken for each of two samples of granular solids to flow through the apparatus. Hold your finger over the lower end of the tubing and carefully fill the tubing and funnel with *all* of sample A. Place the beaker under the bottom of the tube, remove your finger and time the flow of the “fluid” back into the beaker. Repeat this procedure with sample B.

If at any stage of the experiment you spill a significant quantity of either of the samples, or mix the samples together, ask the supervisor to provide you with replacement samples.

time for sample A to flow through the apparatus

time for sample B to flow through the apparatus
(5 marks)

- (b) Use the measuring cylinder to find the volume of each of the samples. For each sample calculate its average rate of flow through the apparatus using the formula

$$\text{average rate of flow} = \frac{\text{volume}}{\text{time}}$$

average rate of flow for sample A

average rate of flow for sample B
(2 marks)

- (c) One of the physical factors expected to affect the rate of flow of granular solids is the grain size. Referring to your results, suggest how grain size affects the rate of flow.

.....

(2 marks)

Question 1 continues on the next page

Turn over for the next question

You are allowed 30 minutes for this question.

- 2 Arrange the apparatus so that the plastic ruler is supported horizontally as shown in **Figure 2**.

Without the load M in position, adjust the apparatus so that the supporting rods are 25 cm apart and the ruler is resting symmetrically upon them.

Figure 2

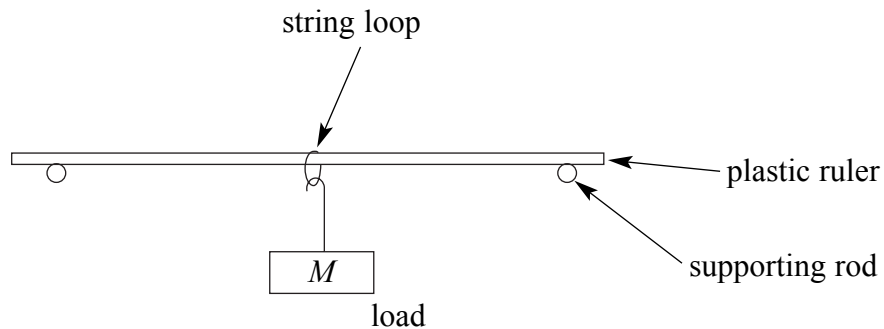

- (a) Measure H_0 , the height of the centre of the ruler above the surface of the bench.

(1 mark)

- (b) (i) With $M = 200$ g, and using the string loop provided, hang the load from the centre of the ruler. Measure H the new height of the centre of the ruler above the bench. Repeat the experiment with $M = 400$ g and $M = 600$ g. Record your measurements in the table given in **Figure 3**.

It is not necessary for you to take repeat readings for each value of M .

- (ii) For each value of M , calculate the sag s using the formula

$$s = H_0 - H$$

Enter these results in the table in **Figure 3**.

Figure 3

M/g	H/cm	s/cm
200		
400		
600		

(3 marks)

- (c) Estimate the absolute uncertainty in your value for s when $M = 200 \text{ g}$. Clearly show your working and state your reasoning.

(3 marks)

- (d) Theory predicts that s is directly proportional to M .

Without plotting a graph, use your data to show whether or not your results support this theory.

conclusion

(3 marks)

Question 2 continues on the next page

The sag s depends not only on the value of M , but also on the dimensions of the ruler and E , the Young modulus of the material from which it is made. It can be shown that

$$E = \frac{kMl^3}{s},$$

where l is the distance between the supporting rods and k is a constant.

- (e) Use your data for $M = 200$ g to estimate the percentage uncertainty in E when calculated using the above formula. You can neglect uncertainties in both k and M .

(3 marks)

Two of the 7 marks in part (f) are available for the quality of your written communication.

- (f) The apparatus can be used to measure E , given that

$$k = \frac{g}{4bd^3},$$

where d is the average thickness of the ruler, b is the width of the ruler and g is the gravitational field strength.

- (i) A major source of uncertainty in E arises from the measurement of d . Explain why this is so and suggest a suitable instrument for measuring d .

.....

.....

.....

.....

.....

- (ii) Apart from the measurement of d , identify sources of uncertainty in this determination of E and describe how you would minimise their effect on the accuracy of the experiment.

.....

.....

.....

.....

.....

.....

.....

.....

.....

.....

.....

.....

.....

.....

.....

(7 marks)

Turn over for the next question

20

You are allowed one hour for this question.

- 3 You are going to investigate a simple network of resistors. The circuit is shown in **Figure 4**.

Figure 4

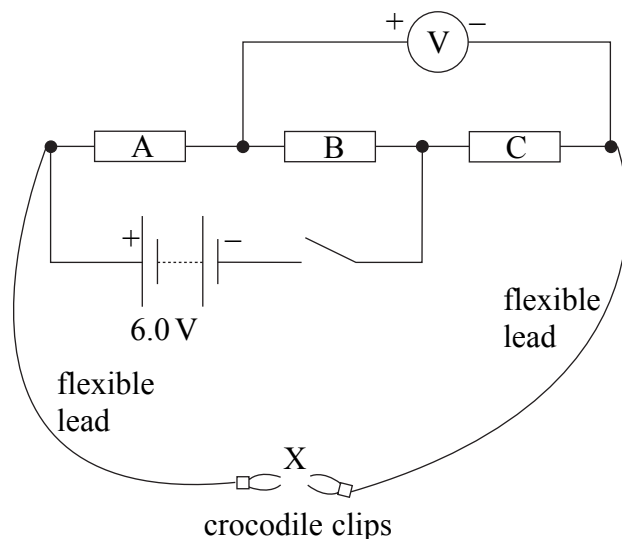

The circuit has been connected for you. A, B and C form a row of three equal fixed resistors. A flexible lead with a crocodile clip has been connected to each end of the row of resistors so that a test resistor R can be clipped into the network at X.

- (a) Ensure that the crocodile clips are not in contact at X and switch on the circuit. Record V_0 , the reading on the voltmeter.

(1 mark)

You are going to connect each of five test resistors into the network at X in turn and record V_x , the value of the voltmeter reading.

Treat all these voltmeter readings as positive values.

- (b) On the blank page opposite construct a table for recording all of your readings and results. Include in this table columns for V and for $\frac{1}{V}$, where

$$V = V_0 + V_x \quad (5 \text{ marks})$$

- (c) Connect resistors with $R = 3.9 \Omega$, 18Ω , 33Ω , 47Ω and 68Ω in turn into the network at X. Record your readings and the corresponding results for V and $\frac{1}{V}$ in your table.

(11 marks)

- (d) (i) Plot a graph of $\frac{1}{V}$ (y -axis) against R (x -axis).
Draw the best straight line through your points.
- (ii) Determine the gradient of your graph.

(10 marks)

The equation for your line is

$$\frac{1}{V} = \frac{R}{2V_0S} + \frac{1}{2V_0}$$

where S is the value of each of the resistors A, B and C.

- (e) Use the intercept on the y -axis of your graph to find a value for V_0 .

(3 marks)

- (f) Use your gradient and your answer to part (e) to find a value for S .

(4 marks)

- (g) Your answer to part (e) should be the same as your answer to part (a).

By considering the apparatus, and the method used, suggest and explain **two** reasons, other than human error, why the answers to parts (a) and (e) may not be the same.

.....
.....
.....
.....
.....
.....
.....
.....

(4 marks)

END OF QUESTIONS