

Surname						Other Names					
Centre Number						Candidate Number					
Candidate Signature											

Leave blank

General Certificate of Education
 January 2003
 Advanced Level Examination



PHYSICS (SPECIFICATION A) PHA9/W
Unit 9 Nuclear Instability: Electronics Option

Monday 27 January 2003 Morning Session

In addition to this paper you will require:

- a calculator;
- a pencil and a ruler.

Time allowed: 1 hour 15 minutes

Instructions

- Use blue or black ink or ball-point pen.
- Fill in the boxes at the top of this page.
- Answer **all** questions in the spaces provided. All working must be shown.
- Do all rough work in this book. Cross through any work you do not want marked.

Information

- The maximum mark for this paper is 40.
- Mark allocations are shown in brackets.
- The paper carries 10% of the total marks for Physics Advanced.
- A *Data Sheet* is provided on pages 3 and 4. You may wish to detach this perforated sheet at the start of the examination.
- You are expected to use a calculator where appropriate.
- In questions requiring description and explanation you will be assessed on your ability to use an appropriate form and style of writing, to organise relevant information clearly and coherently, and to use specialist vocabulary where appropriate. The degree of legibility of your handwriting and the level of accuracy of your spelling, punctuation and grammar will also be taken into account.

For Examiner's Use			
Number	Mark	Number	Mark
1			
2			
3			
4			
Total (Column 1)	→		
Total (Column 2)	→		
TOTAL			
Examiner's Initials			

Data Sheet

- A perforated *Data Sheet* is provided as pages 3 and 4 of this question paper.
- This sheet may be useful for answering some of the questions in the examination.
- You may wish to detach this sheet before you begin work.

Fundamental constants and values

Quantity	Symbol	Value	Units
speed of light in vacuo	c	3.00×10^8	m s^{-1}
permeability of free space	μ_0	$4\pi \times 10^{-7}$	H m^{-1}
permittivity of free space	ϵ_0	8.85×10^{-12}	F m^{-1}
charge of electron	e	1.60×10^{-19}	C
the Planck constant	h	6.63×10^{-34}	J s
gravitational constant	G	6.67×10^{-11}	$\text{N m}^2 \text{kg}^{-2}$
the Avogadro constant	N_A	6.02×10^{23}	mol^{-1}
molar gas constant	R	8.31	$\text{J K}^{-1} \text{mol}^{-1}$
the Boltzmann constant	k	1.38×10^{-23}	J K^{-1}
the Stefan constant	σ	5.67×10^{-8}	$\text{W m}^{-2} \text{K}^{-4}$
the Wien constant	α	2.90×10^{-3}	m K
electron rest mass	m_e	9.11×10^{-31}	kg
(equivalent to $5.5 \times 10^{-4}u$)			
electron charge/mass ratio	e/m_e	1.76×10^{11}	C kg^{-1}
proton rest mass	m_p	1.67×10^{-27}	kg
(equivalent to 1.00728u)			
proton charge/mass ratio	e/m_p	9.58×10^7	C kg^{-1}
neutron rest mass	m_n	1.67×10^{-27}	kg
(equivalent to 1.00867u)			
gravitational field strength	g	9.81	N kg^{-1}
acceleration due to gravity	g	9.81	m s^{-2}
atomic mass unit	u	1.661×10^{-27}	kg
(1u is equivalent to 931.3 MeV)			

Fundamental particles

Class	Name	Symbol	Rest energy /MeV
photon	photon	γ	0
lepton	neutrino	ν_e	0
		ν_μ	0
	electron	e^\pm	0.510999
	muon	μ^\pm	105.659
mesons	pion	π^\pm	139.576
		π^0	134.972
	kaon	K^\pm	493.821
		K^0	497.762
baryons	proton	p	938.257
	neutron	n	939.551

Properties of quarks

Type	Charge	Baryon number	Strangeness
u	$+\frac{2}{3}$	$+\frac{1}{3}$	0
d	$-\frac{1}{3}$	$+\frac{1}{3}$	0
s	$-\frac{1}{3}$	$+\frac{1}{3}$	-1

Geometrical equations

- arc length = $r\theta$
- circumference of circle = $2\pi r$
- area of circle = πr^2
- area of cylinder = $2\pi rh$
- volume of cylinder = $\pi r^2 h$
- area of sphere = $4\pi r^2$
- volume of sphere = $\frac{4}{3}\pi r^3$

Mechanics and Applied Physics

- $v = u + at$
- $s = \left(\frac{u+v}{2}\right)t$
- $s = ut + \frac{at^2}{2}$
- $v^2 = u^2 + 2as$
- $F = \frac{\Delta(mv)}{\Delta t}$
- $P = Fv$
- efficiency = $\frac{\text{power output}}{\text{power input}}$
- $\omega = \frac{v}{r} = 2\pi f$
- $a = \frac{v^2}{r} = r\omega^2$
- $I = \sum mr^2$
- $E_k = \frac{1}{2}I\omega^2$
- $\omega_2 = \omega_1 + at$
- $\theta = \omega_1 t + \frac{1}{2}at^2$
- $\omega_2^2 = \omega_1^2 + 2a\theta$
- $\theta = \frac{1}{2}(\omega_1 + \omega_2)t$
- $T = I\alpha$
- angular momentum = $I\omega$
- $W = T\theta$
- $P = T\omega$
- angular impulse = change of angular momentum = Tt
- $\Delta Q = \Delta U + \Delta W$
- $\Delta W = p\Delta V$
- $pV^\gamma = \text{constant}$
- work done per cycle = area of loop
- input power = calorific value \times fuel flow rate
- indicated power as (area of $p-V$ loop) \times (no. of cycles/s) \times (no. of cylinders)
- friction power = indicated power - brake power
- efficiency = $\frac{W}{Q_{in}} = \frac{Q_{in} - Q_{out}}{Q_{in}}$
- maximum possible efficiency = $\frac{T_H - T_C}{T_H}$

Fields, Waves, Quantum Phenomena

- $g = \frac{F}{m}$
- $g = -\frac{GM}{r^2}$
- $g = -\frac{\Delta V}{\Delta x}$
- $V = -\frac{GM}{r}$
- $a = -(2\pi f)^2 x$
- $v = \pm 2\pi f \sqrt{A^2 - x^2}$
- $x = A \cos 2\pi ft$
- $T = 2\pi \sqrt{\frac{m}{k}}$
- $T = 2\pi \sqrt{\frac{l}{g}}$
- $\lambda = \frac{\omega s}{D}$
- $d \sin \theta = n\lambda$
- $\theta \approx \frac{\lambda}{D}$
- $n_2 = \frac{\sin \theta_1}{\sin \theta_2} = \frac{c_1}{c_2}$
- $n_2 = \frac{n_2}{n_1}$
- $\sin \theta_c = \frac{1}{n}$
- $E = hf$
- $hf = \phi + E_k$
- $hf = E_1 - E_2$
- $\lambda = \frac{h}{p} = \frac{h}{mv}$
- $c = \frac{1}{\sqrt{\mu_0 \epsilon_0}}$
- Electricity**
- $\epsilon = \frac{E}{Q}$
- $\epsilon = I(R+r)$
- $\frac{1}{R_T} = \frac{1}{R_1} + \frac{1}{R_2} + \frac{1}{R_3} + \dots$
- $R_T = R_1 + R_2 + R_3 + \dots$
- $P = I^2 R$
- $E = \frac{F}{Q} = \frac{V}{d}$
- $E = \frac{1}{4\pi \epsilon_0} \frac{Q}{r^2}$
- $E = \frac{1}{2} QV$
- $F = BI$
- $F = BQv$
- $Q = Q_0 e^{-t/RC}$
- $\Phi = BA$

$$\text{magnitude of induced e.m.f.} = N \frac{\Delta\Phi}{\Delta t}$$

$$I_{\text{rms}} = \frac{I_0}{\sqrt{2}}$$

$$V_{\text{rms}} = \frac{V_0}{\sqrt{2}}$$

Mechanical and Thermal Properties

$$\text{the Young modulus} = \frac{\text{tensile stress}}{\text{tensile strain}} = \frac{F}{A} \frac{l}{e}$$

$$\text{energy stored} = \frac{1}{2} Fe$$

$$\Delta Q = mc \Delta\theta$$

$$\Delta Q = ml$$

$$pV = \frac{1}{3} Nmc^2$$

$$\frac{1}{2} mc^2 = \frac{3}{2} kT = \frac{3RT}{2N_A}$$

Nuclear Physics and Turning Points in Physics

$$\text{force} = \frac{eV_p}{d}$$

$$\text{force} = Bev$$

$$\text{radius of curvature} = \frac{mv}{Be}$$

$$\frac{eV}{d} = mg$$

$$\text{work done} = eV$$

$$F = 6\pi\eta rv$$

$$I = k \frac{I_0}{x^2}$$

$$\frac{\Delta N}{\Delta t} = -\lambda N$$

$$\lambda = \frac{h}{\sqrt{2meV}}$$

$$N = N_0 e^{-\lambda t}$$

$$T_{\frac{1}{2}} = \frac{\ln 2}{\lambda}$$

$$R = r_0 A^{\frac{1}{3}}$$

$$E = mc^2 = \frac{m_0 c^2}{\left(1 - \frac{v^2}{c^2}\right)^{\frac{1}{2}}}$$

$$l = l_0 \left(1 - \frac{v^2}{c^2}\right)^{\frac{1}{2}}$$

$$t = \frac{t_0}{\left(1 - \frac{v^2}{c^2}\right)^{\frac{1}{2}}}$$

Astrophysics and Medical Physics

Body	Mass/kg	Mean radius/m
Sun	2.00×10^{30}	7.00×10^8
Earth	6.00×10^{24}	6.40×10^6

$$1 \text{ astronomical unit} = 1.50 \times 10^{11} \text{ m}$$

$$1 \text{ parsec} = 206265 \text{ AU} = 3.08 \times 10^{16} \text{ m} = 3.26 \text{ ly}$$

$$1 \text{ light year} = 9.45 \times 10^{15} \text{ m}$$

$$\text{Hubble constant } (H) = 65 \text{ km s}^{-1} \text{ Mpc}^{-1}$$

$$M = \frac{\text{angle subtended by image at eye}}{\text{angle subtended by object at unaided eye}}$$

$$M = \frac{f_o}{f_e}$$

$$m - M = 5 \log \frac{d}{10}$$

$$\lambda_{\text{max}} T = \text{constant} = 0.0029 \text{ m K}$$

$$v = Hd$$

$$P = \sigma AT^4$$

$$\frac{\Delta f}{f} = \frac{v}{c}$$

$$\frac{\Delta \lambda}{\lambda} = -\frac{v}{c}$$

$$R_s \approx \frac{2GM}{c^2}$$

Medical Physics

$$\text{power} = \frac{1}{f}$$

$$\frac{1}{u} + \frac{1}{v} = \frac{1}{f} \text{ and } m = \frac{v}{u}$$

$$\text{intensity level} = 10 \log \frac{I}{I_0}$$

$$I = I_0 e^{-\mu x}$$

$$\mu_m = \frac{\mu}{\rho}$$

Electronics

Resistors

Preferred values for resistors (E24)

Series: 1.0 1.1 1.2 1.3 1.5 1.6 1.8 2.0 2.2 2.4 2.7 3.0 3.3 3.6 3.9 4.3 4.7 5.1 5.6 6.2 6.8 7.5 8.2 9.1 ohms

and multiples that are ten times greater

$$Z = \frac{V_{\text{rms}}}{I_{\text{rms}}}$$

$$\frac{1}{C_T} = \frac{1}{C_1} + \frac{1}{C_2} + \frac{1}{C_3} + \dots$$

$$C_T = C_1 + C_2 + C_3 + \dots$$

$$X_C = \frac{1}{2\pi f C}$$

Alternating Currents

$$f = \frac{1}{T}$$

Operational amplifier

$$G = \frac{V_{\text{out}}}{V_{\text{in}}} \quad \text{voltage gain}$$

$$G = -\frac{R_f}{R_1} \quad \text{inverting}$$

$$G = 1 + \frac{R_f}{R_1} \quad \text{non-inverting}$$

$$V_{\text{out}} = -R_f \left(\frac{V_1}{R_1} + \frac{V_2}{R_2} + \frac{V_3}{R_3} \right) \quad \text{summing}$$

TURN OVER FOR THE FIRST QUESTION

SECTION A NUCLEAR INSTABILITY

Answer **all** parts of the question.

- 1 The radioactive isotope of sodium ${}_{11}^{22}\text{Na}$ has a half life of 2.6 years. A particular sample of this isotope has an initial activity of 5.5×10^5 Bq (disintegrations per second).

(a) Explain what is meant by the *random nature* of radioactive decay.

You may be awarded marks for the quality of written communication provided in your answer.

.....

.....

.....

.....

.....

(2 marks)

(b) Use the axes to sketch a graph of the activity of the sample of sodium over a period of 6 years.

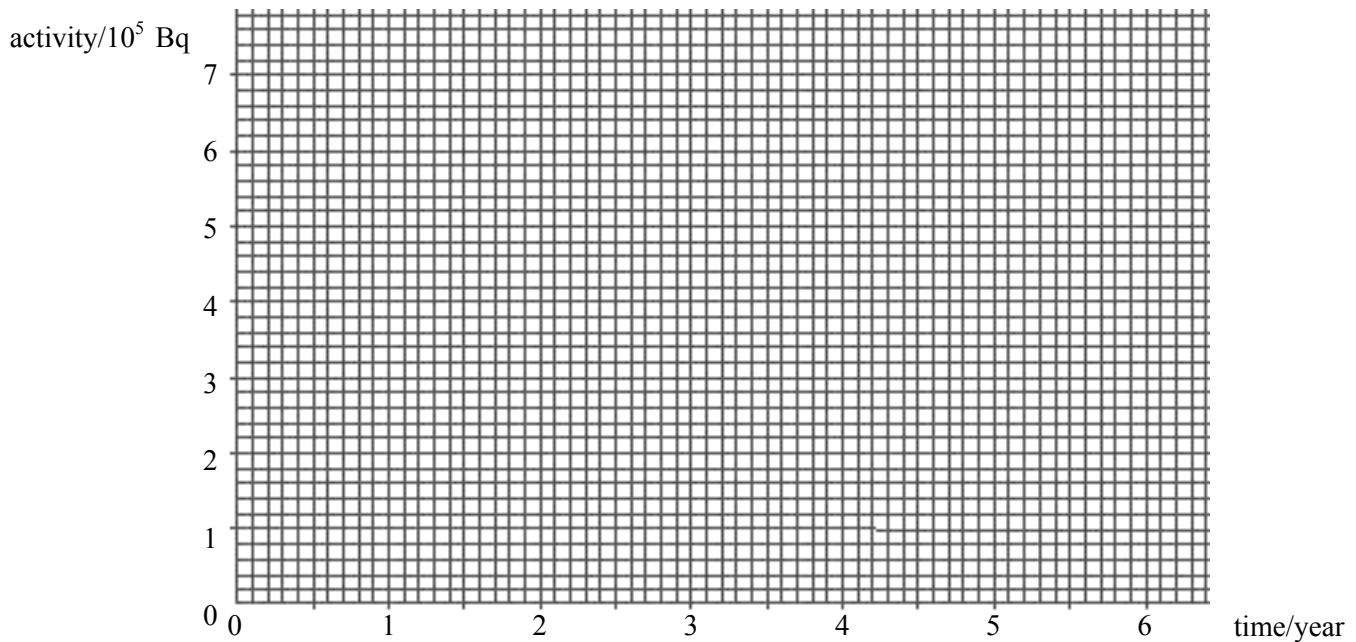

(2 marks)

(c) Calculate

- (i) the decay constant, in s^{-1} , of ${}^{22}_{11}\text{Na}$,
1 year = $3.15 \times 10^7 \text{s}$

.....
.....
.....
.....

- (ii) the number of atoms of ${}^{22}_{11}\text{Na}$ in the sample initially,

.....
.....
.....
.....

- (iii) the time taken, in s, for the activity of the sample to fall from $1.0 \times 10^5 \text{ Bq}$ to $0.75 \times 10^5 \text{ Bq}$.

.....
.....
.....
.....

(6 marks)

10

TURN OVER FOR THE NEXT QUESTION

SECTION B: ELECTRONICS

Answer **all** questions in the spaces provided

- 2 (a) **Figure 1** shows the circuit of a half-wave rectified power supply obtained from an alternating supply of 10 V rms at a frequency of 50 Hz. An oscilloscope is connected across the load resistor R. Assume that the potential drop across the diode is 0.6 V.

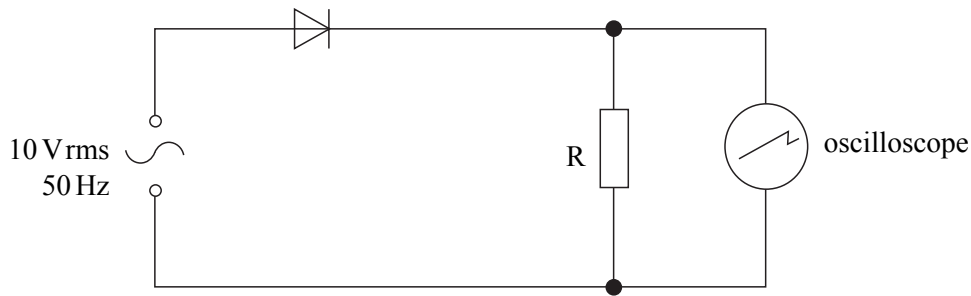
**Figure 1**

- (i) Calculate the peak voltage value of the alternating supply.

.....

- (ii) Draw on the grid below the trace that will be seen on the oscilloscope screen.

time base setting = 5 ms div⁻¹

Y sensitivity = 5 V div⁻¹

.....

.....

.....

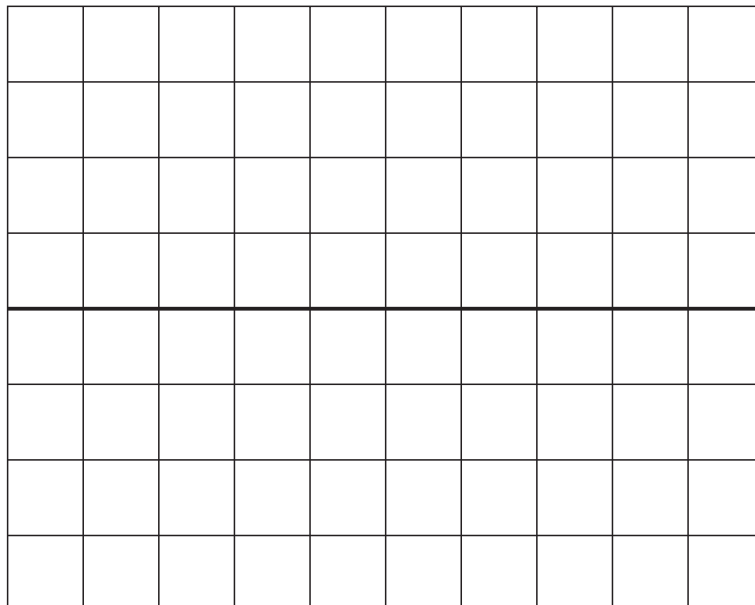

(5 marks)

- (b) Using the same alternating source as in part (a), two diodes, D_1 and D_2 , are incorporated into a signalling system as shown in the circuit in **Figure 2**. Each diode has a potential drop of 0.6 V across it.

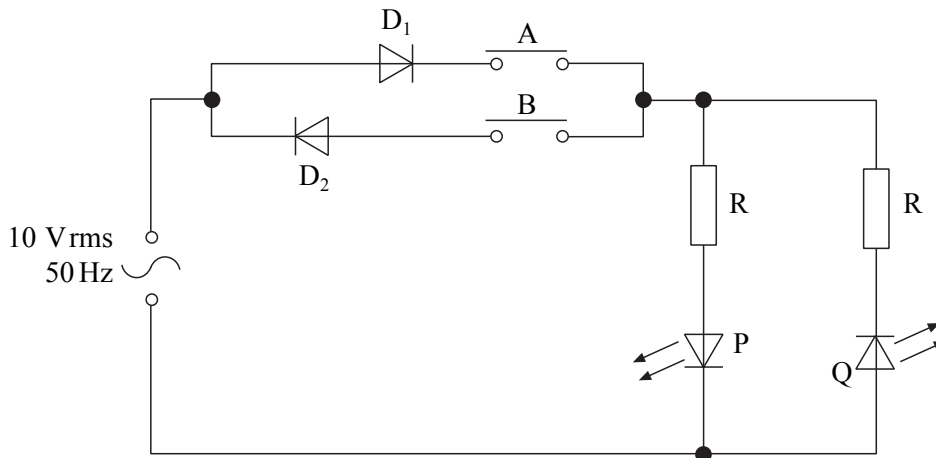

Figure 2

When either switch A or switch B is closed, one of the LEDs, P or Q, will light. The LEDs have a forward voltage drop of 2.0 V and a maximum forward current of 25 mA .

- (i) Explaining your answer, state which LED will light when switch B is closed.

.....

.....

.....

.....

- (ii) Calculate the minimum preferred value for each of the resistors R, using the E24 series.

.....

.....

.....

.....

.....

.....

.....

.....

(5 marks)

3 (a) State **two** characteristics of an operational amplifier.

.....
.....
(2 marks)

(b) (i) Draw a circuit diagram showing an operational amplifier used as an inverting voltage amplifier.

(ii) Give suitable values for the components you have used in the circuit for a voltage amplification of magnitude 150.

.....
.....
.....
(4 marks)

(c) When *negative feedback* is used with an amplifier the bandwidth increases.

(i) Explain what is meant by negative feedback as applied to the circuit drawn in part (b).

.....

.....

.....

(ii) Give **one** other advantage of using negative feedback in this application.

.....

(iii) State what is meant by the bandwidth of an amplifier.

.....

.....

(iv) Indicate on the graph below, by means of a horizontal line, the bandwidth of the amplifier whose characteristic is shown.

.....

.....

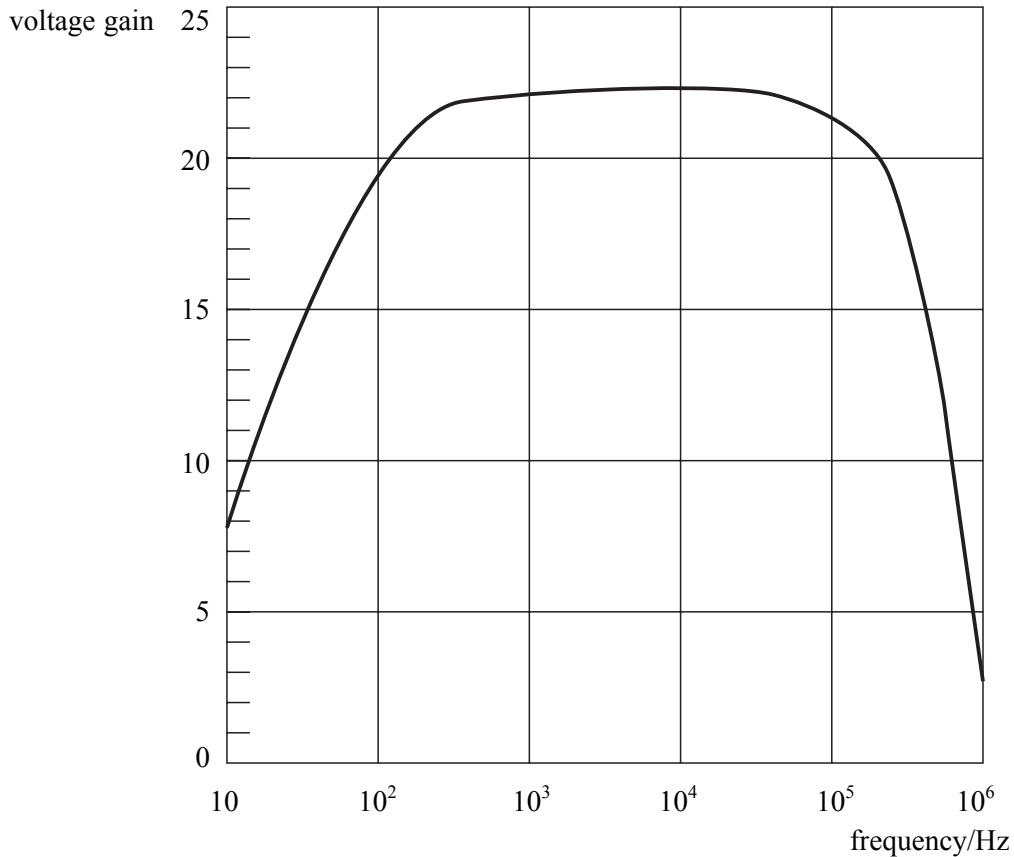

(5 marks)

- 4 Different parts of a circuit are often coupled together by a capacitor and a resistor as shown in **Figure 3**. The output waveform depends on the time constant of the coupling circuit.

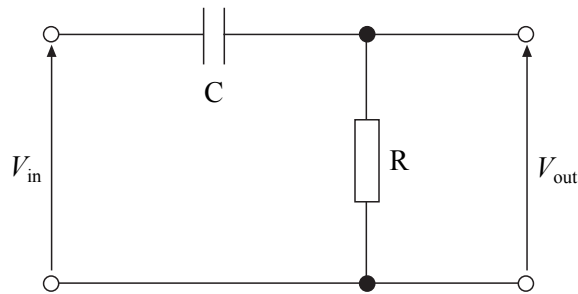

Figure 3

Figure 4 shows the input signal V_{in} , as a function of time.

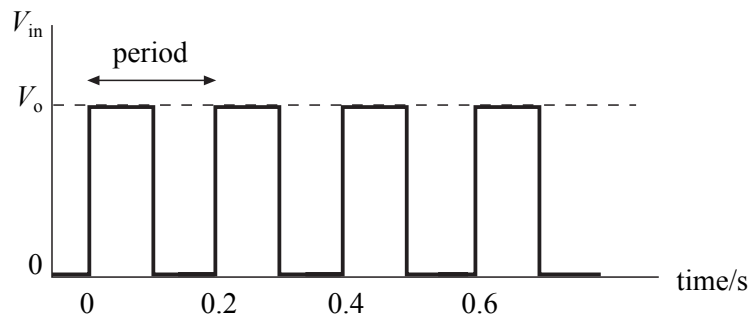

Figure 4

- (a) **Figure 5** shows the output signal, V_{out} , obtained when $R = 200 \text{ k}\Omega$ and $C = 0.10 \mu\text{F}$.

- (i) Calculate the time constant of the circuit.

.....

- (ii) Explain the form of the output voltage signal.

You may be awarded marks for the quality of written communication in your answer.

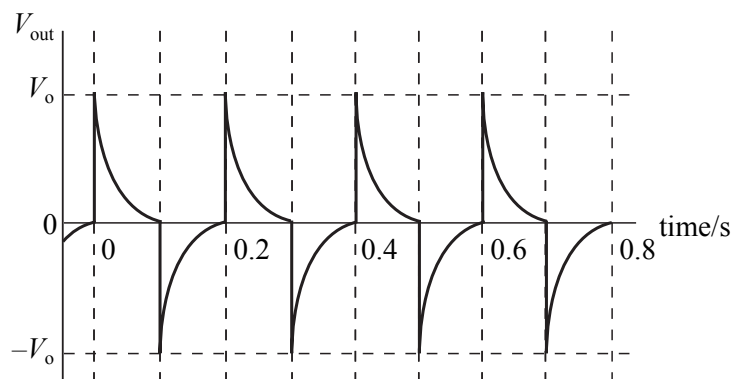

Figure 5

.....

.....

.....

.....

.....

.....

(4 marks)

(b) R is now changed to $2.0\text{ M}\Omega$ and C remains at $0.10\text{ }\mu\text{F}$.

(i) Calculate the new time constant.

.....

(ii) Sketch on the axes below the form of the output signal. The time scale is the same as that in **Figure 5**.

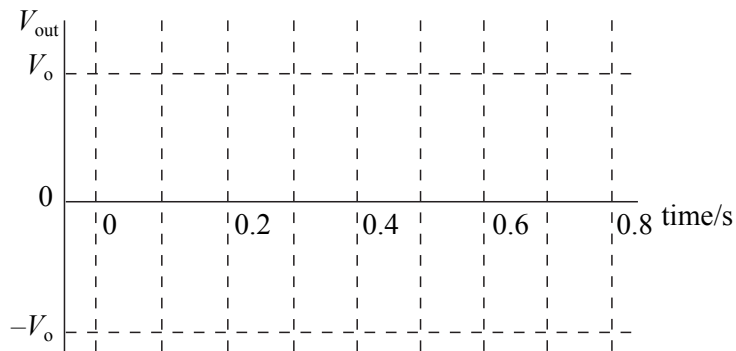

(iii) Explain, without further calculation, the form of the output signal you have drawn.

.....

.....

.....

(3 marks)

QUALITY OF WRITTEN COMMUNICATION (2 marks)

END OF QUESTIONS

$\frac{7}{-}$

$\frac{2}{-}$