

Surname						Other Names					
Centre Number						Candidate Number					
Candidate Signature											

Leave blank

General Certificate of Education  
 January 2003  
 Advanced Level Examination



**PHYSICS (SPECIFICATION A)**  
**Unit 7 Nuclear Instability: Applied Physics Option**

**PHA7/W**

Monday 27 January 2003 Morning Session

**In addition to this paper you will require:**

- a calculator;
- a pencil and a ruler.

Time allowed: 1 hour 15 minutes

**Instructions**

- Use blue or black ink or ball-point pen.
- Fill in the boxes at the top of this page.
- Answer **all** questions in the spaces provided. All working must be shown.
- Do all rough work in this book. Cross through any work you do not want marked.

**Information**

- The maximum mark for this paper is 40.
- Mark allocations are shown in brackets.
- The paper carries 10% of the total marks for Physics Advanced.
- A *Data Sheet* is provided on pages 3 and 4. You may wish to detach this perforated sheet at the start of the examination.
- You are expected to use a calculator where appropriate.
- In questions requiring description and explanation you will be assessed on your ability to use an appropriate form and style of writing, to organise relevant information clearly and coherently, and to use specialist vocabulary where appropriate. The degree of legibility of your handwriting and the level of accuracy of your spelling, punctuation and grammar will also be taken into account.

For Examiner's Use			
Number	Mark	Number	Mark
1			
2			
3			
4			
5			
Total (Column 1)		→	
Total (Column 2)		→	
TOTAL			
Examiner's Initials			

**Data Sheet**

- A perforated *Data Sheet* is provided as pages 3 and 4 of this question paper.
- This sheet may be useful for answering some of the questions in the examination.
- You may wish to detach this sheet before you begin work.

**Fundamental constants and values**

Quantity	Symbol	Value	Units
speed of light in vacuo	$c$	$3.00 \times 10^8$	$\text{m s}^{-1}$
permeability of free space	$\mu_0$	$4\pi \times 10^{-7}$	$\text{H m}^{-1}$
permittivity of free space	$\epsilon_0$	$8.85 \times 10^{-12}$	$\text{F m}^{-1}$
charge of electron	$e$	$1.60 \times 10^{-19}$	C
the Planck constant	$h$	$6.63 \times 10^{-34}$	J s
gravitational constant	$G$	$6.67 \times 10^{-11}$	$\text{N m}^2 \text{kg}^{-2}$
the Avogadro constant	$N_A$	$6.02 \times 10^{23}$	$\text{mol}^{-1}$
molar gas constant	$R$	8.31	$\text{J K}^{-1} \text{mol}^{-1}$
the Boltzmann constant	$k$	$1.38 \times 10^{-23}$	$\text{J K}^{-1}$
the Stefan constant	$\sigma$	$5.67 \times 10^{-8}$	$\text{W m}^{-2} \text{K}^{-4}$
the Wien constant	$\alpha$	$2.90 \times 10^{-3}$	m K
electron rest mass	$m_e$	$9.11 \times 10^{-31}$	kg
(equivalent to $5.5 \times 10^{-4}u$ )			
electron charge/mass ratio	$e/m_e$	$1.76 \times 10^{11}$	$\text{C kg}^{-1}$
proton rest mass	$m_p$	$1.67 \times 10^{-27}$	kg
(equivalent to 1.00728u)			
proton charge/mass ratio	$e/m_p$	$9.58 \times 10^7$	$\text{C kg}^{-1}$
neutron rest mass	$m_n$	$1.67 \times 10^{-27}$	kg
(equivalent to 1.00867u)			
gravitational field strength	$g$	9.81	$\text{N kg}^{-1}$
acceleration due to gravity	$g$	9.81	$\text{m s}^{-2}$
atomic mass unit	$u$	$1.661 \times 10^{-27}$	kg
(1u is equivalent to 931.3 MeV)			

**Fundamental particles**

Class	Name	Symbol	Rest energy /MeV
photon	photon	$\gamma$	0
lepton	neutrino	$\nu_e$	0
		$\nu_\mu$	0
	electron	$e^\pm$	0.510999
	muon	$\mu^\pm$	105.659
mesons	pion	$\pi^\pm$	139.576
		$\pi^0$	134.972
	kaon	$K^\pm$	493.821
		$K^0$	497.762
baryons	proton	p	938.257
	neutron	n	939.551

**Properties of quarks**

Type	Charge	Baryon number	Strangeness
u	$+\frac{2}{3}$	$+\frac{1}{3}$	0
d	$-\frac{1}{3}$	$+\frac{1}{3}$	0
s	$-\frac{1}{3}$	$+\frac{1}{3}$	-1

**Geometrical equations**

- arc length =  $r\theta$
- circumference of circle =  $2\pi r$
- area of circle =  $\pi r^2$
- area of cylinder =  $2\pi rh$
- volume of cylinder =  $\pi r^2 h$
- area of sphere =  $4\pi r^2$
- volume of sphere =  $\frac{4}{3}\pi r^3$

**Mechanics and Applied Physics**

- $v = u + at$
- $s = \left(\frac{u+v}{2}\right)t$
- $s = ut + \frac{at^2}{2}$
- $v^2 = u^2 + 2as$
- $F = \frac{\Delta(mv)}{\Delta t}$
- $P = Fv$
- efficiency =  $\frac{\text{power output}}{\text{power input}}$
- $\omega = \frac{v}{r} = 2\pi f$
- $a = \frac{v^2}{r} = r\omega^2$
- $I = \sum mr^2$
- $E_k = \frac{1}{2} I\omega^2$
- $\omega_2 = \omega_1 + at$
- $\theta = \omega_1 t + \frac{1}{2} at^2$
- $\omega_2^2 = \omega_1^2 + 2a\theta$
- $\theta = \frac{1}{2} (\omega_1 + \omega_2)t$
- $T = I\alpha$
- angular momentum =  $I\omega$
- $W = T\theta$
- $P = T\omega$
- angular impulse = change of angular momentum =  $Tt$
- $\Delta Q = \Delta U + \Delta W$
- $\Delta W = p\Delta V$
- $pV^\gamma = \text{constant}$
- work done per cycle = area of loop
- input power = calorific value  $\times$  fuel flow rate
- indicated power as (area of  $p - V$  loop)  $\times$  (no. of cycles/s)  $\times$  (no. of cylinders)
- friction power = indicated power - brake power
- efficiency =  $\frac{W}{Q_{in}} = \frac{Q_{in} - Q_{out}}{Q_{in}}$
- maximum possible efficiency =  $\frac{T_H - T_C}{T_H}$

**Fields, Waves, Quantum Phenomena**

- $g = \frac{F}{m}$
- $g = -\frac{GM}{r^2}$
- $g = -\frac{\Delta V}{\Delta x}$
- $V = -\frac{GM}{r}$
- $a = -(2\pi f)^2 x$
- $v = \pm 2\pi f \sqrt{A^2 - x^2}$
- $x = A \cos 2\pi ft$
- $T = 2\pi \sqrt{\frac{m}{k}}$
- $T = 2\pi \sqrt{\frac{l}{g}}$
- $\lambda = \frac{\omega s}{D}$
- $d \sin \theta = n\lambda$
- $\theta \approx \frac{\lambda}{D}$
- $n_2 = \frac{\sin \theta_1}{\sin \theta_2} = \frac{c_1}{c_2}$
- $n_2 = \frac{n_2}{n_1}$
- $\sin \theta_c = \frac{1}{n}$
- $E = hf$
- $hf = \phi + E_k$
- $hf = E_1 - E_2$
- $\lambda = \frac{h}{p} = \frac{h}{mv}$
- $c = \frac{1}{\sqrt{\mu_0 \epsilon_0}}$
- Electricity**
- $\epsilon = \frac{E}{Q}$
- $\epsilon = I(R + r)$
- $\frac{1}{R_T} = \frac{1}{R_1} + \frac{1}{R_2} + \frac{1}{R_3} + \dots$
- $R_T = R_1 + R_2 + R_3 + \dots$
- $P = I^2 R$
- $E = \frac{F}{Q} = \frac{V}{d}$
- $E = \frac{1}{4\pi \epsilon_0} \frac{Q}{r^2}$
- $E = \frac{1}{2} QV$
- $F = BI$
- $F = BQv$
- $Q = Q_0 e^{-t/RC}$
- $\Phi = BA$

$$\text{magnitude of induced e.m.f.} = N \frac{\Delta\Phi}{\Delta t}$$

$$I_{\text{rms}} = \frac{I_0}{\sqrt{2}}$$

$$V_{\text{rms}} = \frac{V_0}{\sqrt{2}}$$

### Mechanical and Thermal Properties

$$\text{the Young modulus} = \frac{\text{tensile stress}}{\text{tensile strain}} = \frac{F}{A} \frac{l}{e}$$

$$\text{energy stored} = \frac{1}{2} Fe$$

$$\Delta Q = mc \Delta\theta$$

$$\Delta Q = ml$$

$$pV = \frac{1}{3} Nmc^2$$

$$\frac{1}{2} mc^2 = \frac{3}{2} kT = \frac{3RT}{2N_A}$$

### Nuclear Physics and Turning Points in Physics

$$\text{force} = \frac{eV_p}{d}$$

$$\text{force} = Bev$$

$$\text{radius of curvature} = \frac{mv}{Be}$$

$$\frac{eV}{d} = mg$$

$$\text{work done} = eV$$

$$F = 6\pi\eta rv$$

$$I = k \frac{I_0}{x^2}$$

$$\frac{\Delta N}{\Delta t} = -\lambda N$$

$$\lambda = \frac{h}{\sqrt{2meV}}$$

$$N = N_0 e^{-\lambda t}$$

$$T_{\frac{1}{2}} = \frac{\ln 2}{\lambda}$$

$$R = r_0 A^{\frac{1}{3}}$$

$$E = mc^2 = \frac{m_0 c^2}{\left(1 - \frac{v^2}{c^2}\right)^{\frac{1}{2}}}$$

$$l = l_0 \left(1 - \frac{v^2}{c^2}\right)^{\frac{1}{2}}$$

$$t = \frac{t_0}{\left(1 - \frac{v^2}{c^2}\right)^{\frac{1}{2}}}$$

### Astrophysics and Medical Physics

Body	Mass/kg	Mean radius/m
Sun	$2.00 \times 10^{30}$	$7.00 \times 10^8$
Earth	$6.00 \times 10^{24}$	$6.40 \times 10^6$

$$1 \text{ astronomical unit} = 1.50 \times 10^{11} \text{ m}$$

$$1 \text{ parsec} = 206265 \text{ AU} = 3.08 \times 10^{16} \text{ m} = 3.26 \text{ ly}$$

$$1 \text{ light year} = 9.45 \times 10^{15} \text{ m}$$

$$\text{Hubble constant } (H) = 65 \text{ km s}^{-1} \text{ Mpc}^{-1}$$

$$M = \frac{\text{angle subtended by image at eye}}{\text{angle subtended by object at unaided eye}}$$

$$M = \frac{f_o}{f_e}$$

$$m - M = 5 \log \frac{d}{10}$$

$$\lambda_{\text{max}} T = \text{constant} = 0.0029 \text{ m K}$$

$$v = Hd$$

$$P = \sigma AT^4$$

$$\frac{\Delta f}{f} = \frac{v}{c}$$

$$\frac{\Delta \lambda}{\lambda} = -\frac{v}{c}$$

$$R_s \approx \frac{2GM}{c^2}$$

### Medical Physics

$$\text{power} = \frac{1}{f}$$

$$\frac{1}{u} + \frac{1}{v} = \frac{1}{f} \text{ and } m = \frac{v}{u}$$

$$\text{intensity level} = 10 \log \frac{I}{I_0}$$

$$I = I_0 e^{-\mu x}$$

$$\mu_m = \frac{\mu}{\rho}$$

### Electronics

Resistors

Preferred values for resistors (E24)  
Series: 1.0 1.1 1.2 1.3 1.5 1.6 1.8 2.0 2.2  
2.4 2.7 3.0 3.3 3.6 3.9 4.3 4.7 5.1 5.6 6.2  
6.8 7.5 8.2 9.1 ohms  
and multiples that are ten times greater

$$Z = \frac{V_{\text{rms}}}{I_{\text{rms}}}$$

$$\frac{1}{C_T} = \frac{1}{C_1} + \frac{1}{C_2} + \frac{1}{C_3} + \dots$$

$$C_T = C_1 + C_2 + C_3 + \dots$$

$$X_C = \frac{1}{2\pi f C}$$

### Alternating Currents

$$f = \frac{1}{T}$$

### Operational amplifier

$$G = \frac{V_{\text{out}}}{V_{\text{in}}} \quad \text{voltage gain}$$

$$G = -\frac{R_f}{R_1} \quad \text{inverting}$$

$$G = 1 + \frac{R_f}{R_1} \quad \text{non-inverting}$$

$$V_{\text{out}} = -R_f \left( \frac{V_1}{R_1} + \frac{V_2}{R_2} + \frac{V_3}{R_3} \right) \quad \text{summing}$$

**SECTION A NUCLEAR INSTABILITY**

Answer **all** parts of the question.

- 1 The radioactive isotope of sodium  ${}_{11}^{22}\text{Na}$  has a half life of 2.6 years. A particular sample of this isotope has an initial activity of  $5.5 \times 10^5$  Bq (disintegrations per second).

(a) Explain what is meant by the *random nature* of radioactive decay.

You may be awarded marks for the quality of written communication provided in your answer.

.....

.....

.....

.....

.....

(2 marks)

(b) Use the axes to sketch a graph of the activity of the sample of sodium over a period of 6 years.

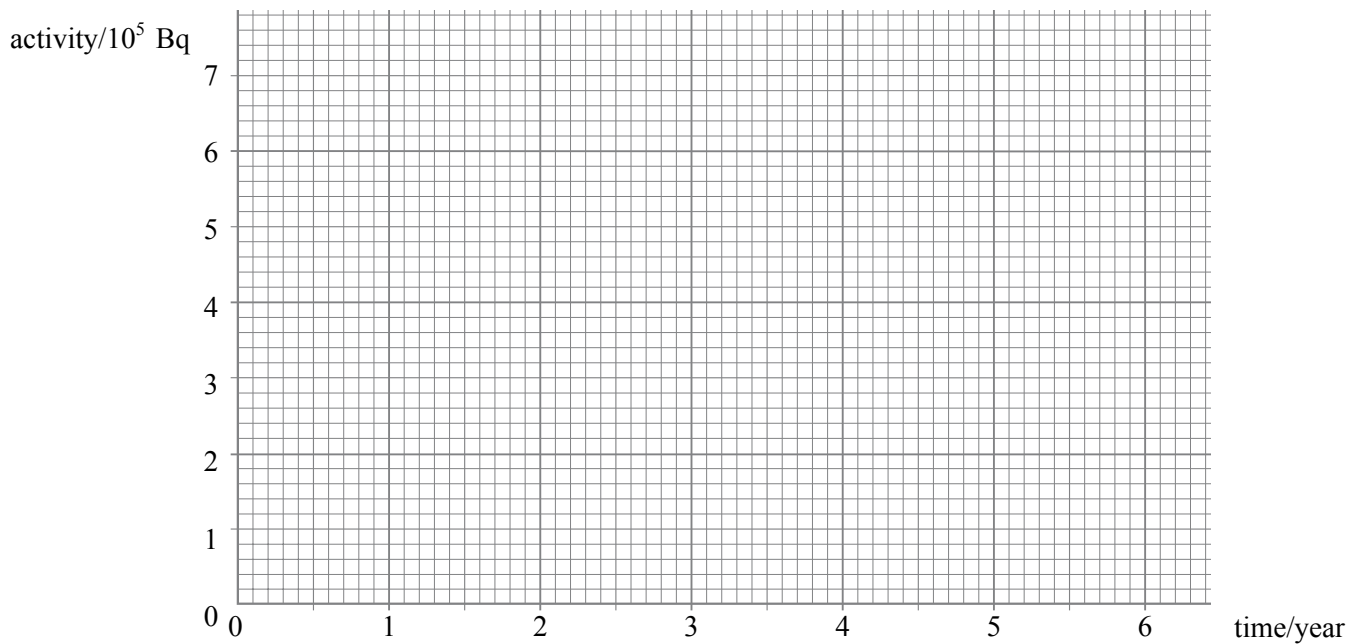

(2 marks)

(c) Calculate

- (i) the decay constant, in  $\text{s}^{-1}$ , of  ${}^{22}_{11}\text{Na}$ ,  
1 year =  $3.15 \times 10^7 \text{s}$

.....

.....

.....

.....

- (ii) the number of atoms of  ${}^{22}_{11}\text{Na}$  in the sample initially,

.....

.....

.....

.....

- (iii) the time taken, in s, for the activity of the sample to fall from  $1.0 \times 10^5 \text{ Bq}$  to  $0.75 \times 10^5 \text{ Bq}$ .

.....

.....

.....

.....

(6 marks)

**TURN OVER FOR THE NEXT QUESTION**

10

## SECTION B APPLIED PHYSICS

Answer **all** questions.

- 2 The diagram shows a street sign designed to rotate under windy conditions.

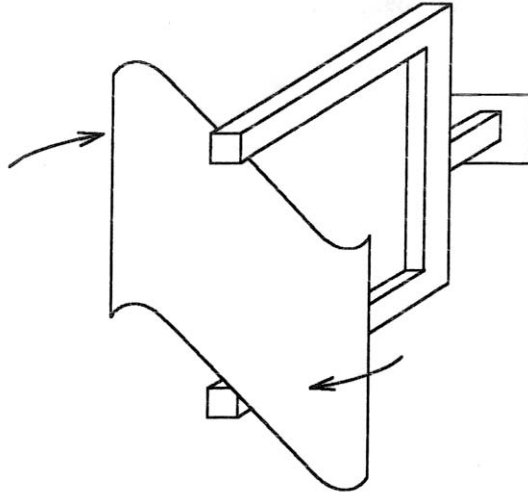

- (a) On a still day, a gust of wind from a passing vehicle imparts an angular impulse of  $1.2 \text{ kg m}^2 \text{ rad s}^{-1}$  to the sign, which accelerates from rest during a time of 2.8 s. The moment of inertia of the sign about its axis of rotation is  $4.8 \times 10^{-2} \text{ kg m}^2$ . Assuming that the frictional couple acting on the sign is negligible, calculate

- (i) the angular momentum acquired by the sign as a result of the angular impulse, showing your reasoning clearly,

.....

.....

.....

- (ii) the angular speed of the sign immediately after the impulse has been imparted,

.....

.....

.....

- (iii) the average torque acting on the sign during the time the impulse was imparted.

.....

.....

.....

(4 marks)

- (b) A second sign, of the same type and with the same moment of inertia, continues to rotate for 14 s after an impulse has been imparted, before friction brings it to rest from an angular speed of  $30 \text{ rad s}^{-1}$ . Calculate the number of complete turns made by the sign during this time.

.....

.....

.....

.....

(2 marks)

6

**TURN OVER FOR THE NEXT QUESTION**



- 3 **Figure 1** shows a human centrifuge used in pilot training to simulate the large 'g' forces experienced by pilots during aerial manoeuvres. The trainee sits in the capsule at the end of the rotating centrifuge arm, which is driven by an electric motor.

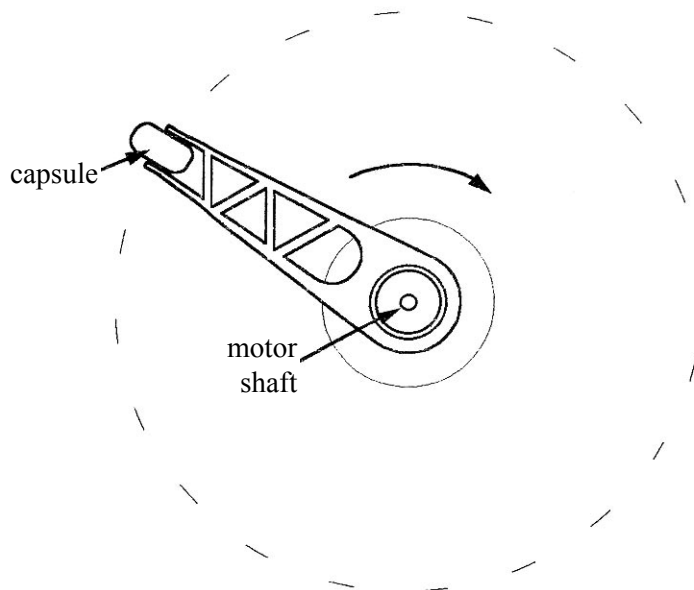

**Figure 1**

- (a) When working at maximum power, the motor is capable of increasing the angular speed of the arm from its minimum working speed of  $1.6 \text{ rad s}^{-1}$  to its maximum speed of  $7.4 \text{ rad s}^{-1}$  in 4.4 s. The net power needed to achieve this acceleration is 150 kW.
- (i) Assuming that this power remains constant during the acceleration, calculate the energy supplied to the centrifuge by the motor.

.....  
 .....

- (ii) Hence estimate the moment of inertia of the rotating system.

.....  
 .....

(4 marks)

- (b) Bending stresses on the central shaft could have been reduced at the design stage by extending the arm beyond the shaft and fixing a counterweight, as shown in **Figure 2**. Its designers rejected this because savings in the manufacturing and maintenance costs of the system would be far less than the increased costs associated with a higher power motor.

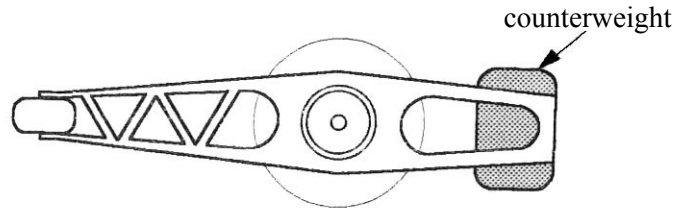

**Figure 2**

State and explain why, apart from increased friction associated with a heavier arm, the use of a counterweight would require greatly increased motor power.  
You may be awarded marks for the quality of written communication provided in your answer.

.....

.....

.....

.....

.....

(2 marks)

6

**TURN OVER FOR THE NEXT QUESTION**

4 Test-bed measurements made on a single-cylinder 4-stroke petrol engine produced the following data:

mean temperature of gases in cylinder during combustion stroke	820 °C
mean temperature of exhaust gases	77 °C
area enclosed by indicator diagram loop	380 J
rotational speed of output shaft	1800 rev min <sup>-1</sup>
power developed by engine at output shaft	4.7 kW
calorific value of fuel	45 MJ kg <sup>-1</sup>
flow rate of fuel	2.1 × 10 <sup>-2</sup> kg min <sup>-1</sup>

(a) Estimate the maximum theoretical efficiency of this engine.

.....  
 .....  
 .....

(2 marks)

(b) Calculate the indicated power of the engine.

.....  
 .....  
 .....

(2 marks)

(c) Calculate the power dissipated in overcoming the frictional losses in the engine.

.....  
 .....

(1 mark)

(d) Calculate the rate at which energy is supplied to the engine.

.....  
 .....  
 .....

(1 mark)

(e) Calculate the overall efficiency of the engine.

.....  
 .....  
 .....

(1 mark)

- 5 The  $pV$  diagram shows a cycle in which a fixed mass of an ideal gas is taken through the following processes:  $A \rightarrow B$  isothermal compression,  $B \rightarrow C$  expansion at constant pressure,  $C \rightarrow A$  reduction in pressure at constant volume.

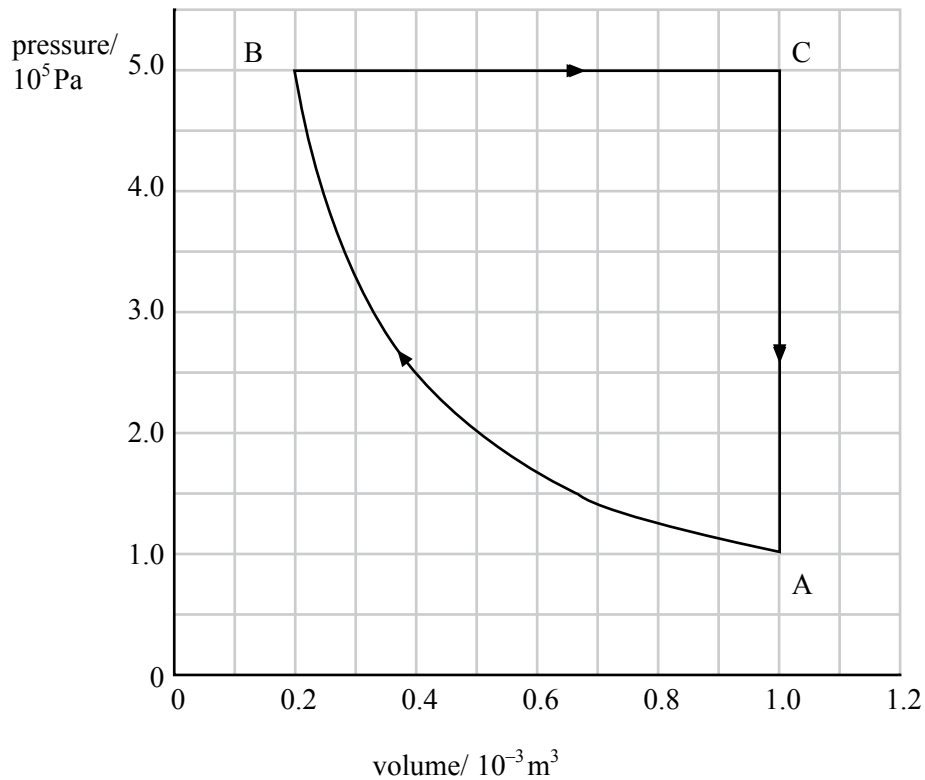

- (a) Show that the compression in process  $A \rightarrow B$  is isothermal.

.....  
 .....  
 .....

(2 marks)

- (b) In which **two** of the three processes must heat be removed from the gas?

.....

(1 mark)

- (c) Calculate the work done by the gas during process  $B \rightarrow C$ .

.....  
 .....  
 .....

(2 marks)

(d) The cycle shown in the diagram involves  $6.9 \times 10^{-2}$  mol of gas.

(i) At which point in the cycle is the temperature of the gas greatest?

.....

(ii) Calculate the temperature of the gas at this point.

.....

.....

.....

.....

(4 marks)

**QUALITY OF WRITTEN COMMUNICATION** (2 marks)

**END OF QUESTIONS**

9

2