

Surname						Other Names					
Centre Number						Candidate Number					
Candidate Signature											

Leave blank
-------------

General Certificate of Education  
 June 2006  
 Advanced Subsidiary Examination



**BIOLOGY (SPECIFICATION B)**  
**Unit 3 Physiology and Transport**

**BYB3/W**

Monday 5 June 2006 9.00 am to 10.00 am

**For this paper you must have:**

- a ruler with millimetre measurements

You may use a calculator.

Time allowed: 1 hour

**Instructions**

- Use blue or black ink or ball-point pen.
- Fill in the boxes at the top of this page.
- Answer **all** questions.
- Answer the questions in the spaces provided.
- Do all rough work in this book. Cross through any work you do not want marked.

**Information**

- The maximum mark for this paper is 54.
- The marks for part questions are shown in brackets.
- You are reminded of the need for good English and clear presentation in your answers.
- Use accurate scientific terminology in your answers.
- Answers for **Questions 1 to 7** are expected to be short and precise.
- Answer **Question 8** in continuous prose. Quality of Written Communication will be assessed in the answer.

For Examiner's Use			
Number	Mark	Number	Mark
1			
2			
3			
4			
5			
6			
7			
8			
Total (Column 1) →			
Total (Column 2) →			
Quality of Written Communication			
TOTAL			
Examiner's Initials			

Answer **all** questions in the spaces provided.

- 1 (a) **Figure 1** shows a section through the root of a young plant.

**Figure 1**

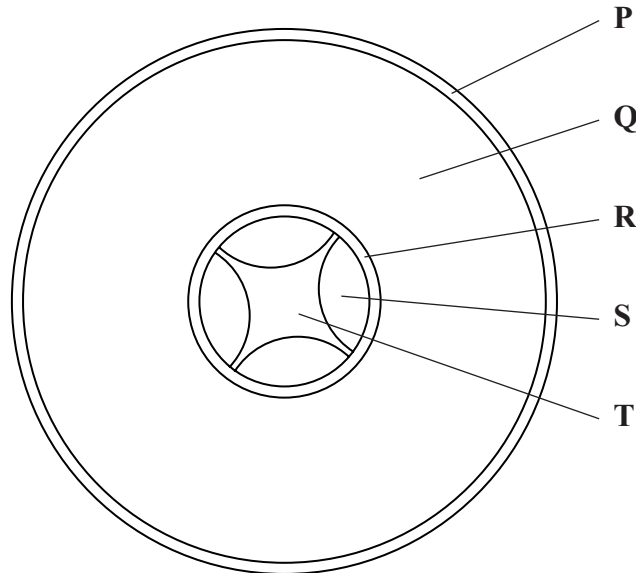

- (i) Name the part of the plant labelled **R**.

.....  
(1 mark)

- (ii) Give the letter which labels a tissue that transports solutes from the leaves.

Answer .....  
(1 mark)

- (iii) Give the letter which labels a tissue that prevents the movement of water through the apoplast pathway.

Answer .....  
(1 mark)

(b) **Figure 2** shows a single stoma and surrounding cells from the leaf of a xerophytic plant.

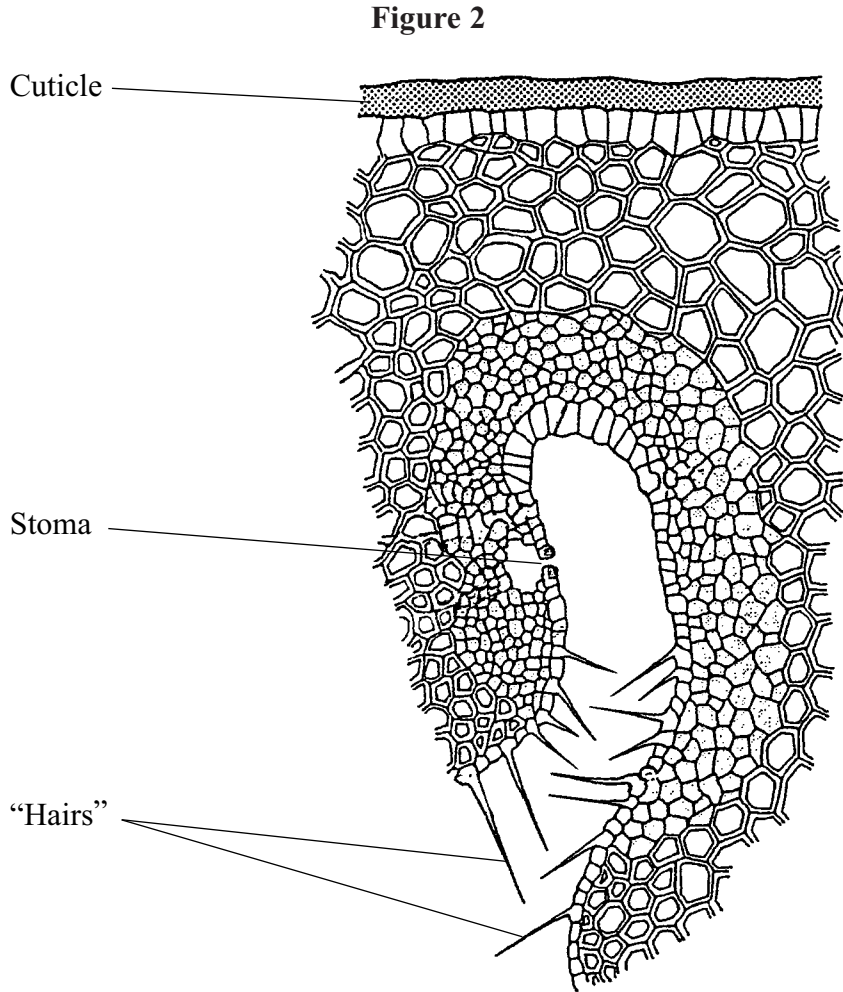

(i) Explain how the cuticle reduces water loss.

.....  
.....

(1 mark)

(ii) Explain how **one** of the other labelled parts reduces water loss.

.....  
.....  
.....  
.....

(2 marks)

- 2 The graph shows changes in pressure in different parts of the heart during a period of one second.

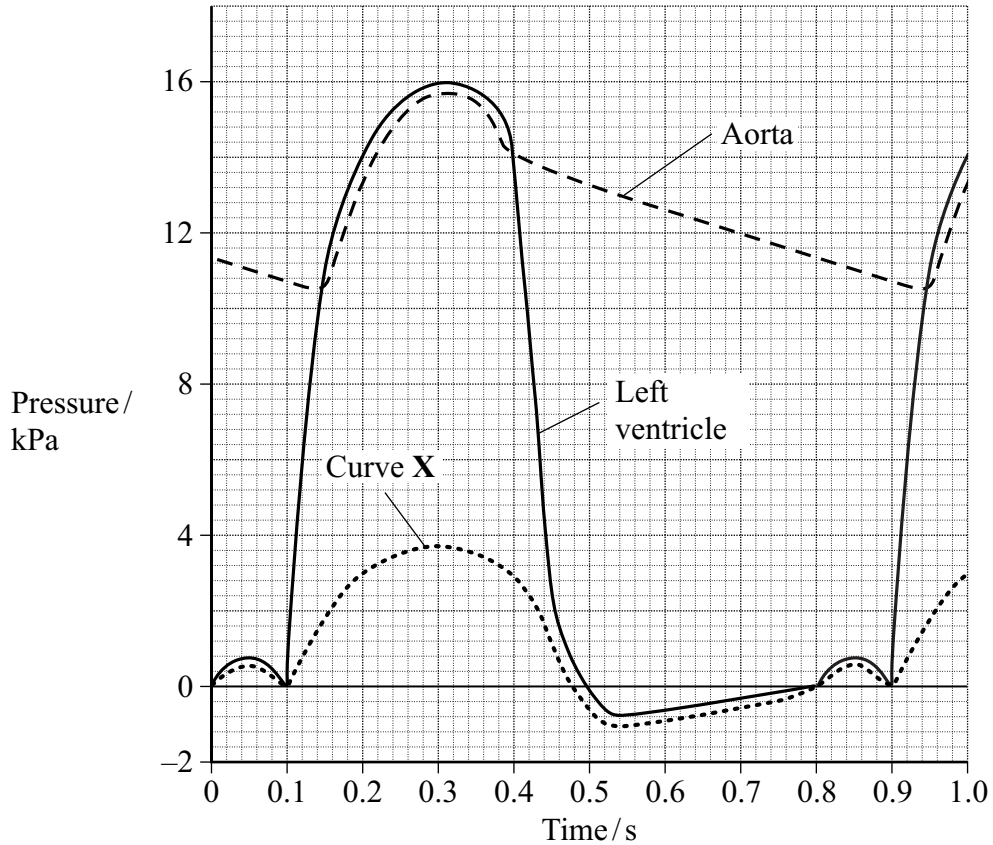

- (a) (i) At what time do the semilunar valves close?

.....  
(1 mark)

- (ii) Use the graph to calculate the heart rate in beats per minute.  
Show your working.

Answer ..... beats per minute  
(1 mark)

- (iii) Use the graph to calculate the total time that blood flows out of the left side of the heart during one minute when beating at this rate. Show your working.

Answer ..... seconds  
(1 mark)

(b) What does curve **X** represent? Explain your answer.

**X** = .....

Explanation .....

.....

(2 marks)

(c) The volume of blood pumped out of the left ventricle during one cardiac cycle is called the stroke volume.

The volume of blood pumped out of the left ventricle in one minute is called the cardiac output. It is calculated using the equation

$$\text{Cardiac output} = \text{stroke volume} \times \text{heart rate}$$

After several months of training, an athlete had the same cardiac output but a lower resting heart rate than before. Explain this change.

.....

.....

.....

.....

(2 marks)

7

**Turn over for the next question**

- 3 The volumes of water absorbed by the roots of a plant and lost by transpiration were measured over periods of 4 hours during one day. The bar chart shows the results.

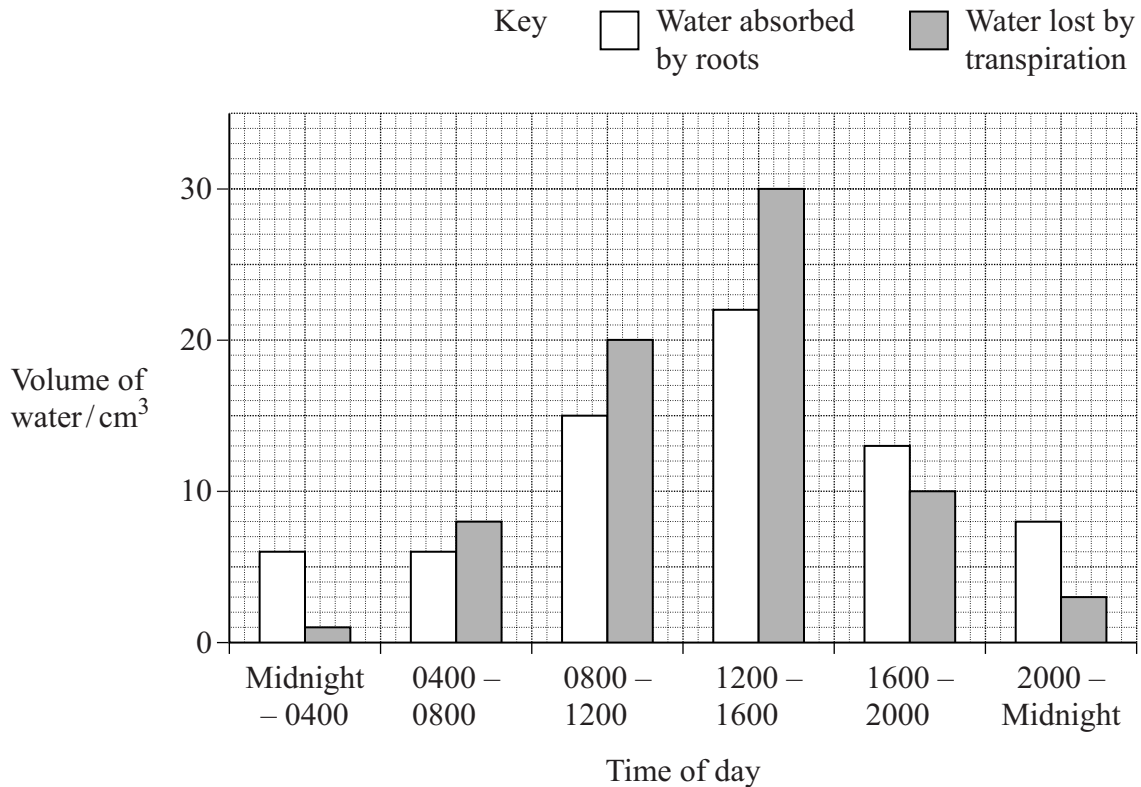

- (a) (i) Describe the changes in the volumes of water absorbed and transpired between midnight and 1600.

.....

.....

.....

.....

(2 marks)

- (ii) Explain these changes in the volumes.

.....

.....

.....

.....

(2 marks)

(b) Use your knowledge of the cohesion-tension theory to explain how water in the xylem in the roots moves up the stem.

.....

.....

.....

.....

.....

.....

.....

.....

.....

*(4 marks)*

<b>8</b>

**Turn over for the next question**

- 4 One leaf on a young plant was supplied with carbon dioxide containing the radioactive isotope of carbon,  $^{14}\text{C}$ . The plant was kept in bright light for one hour. The amount of radioactivity was then measured at three places in the plant. The diagram shows the results.

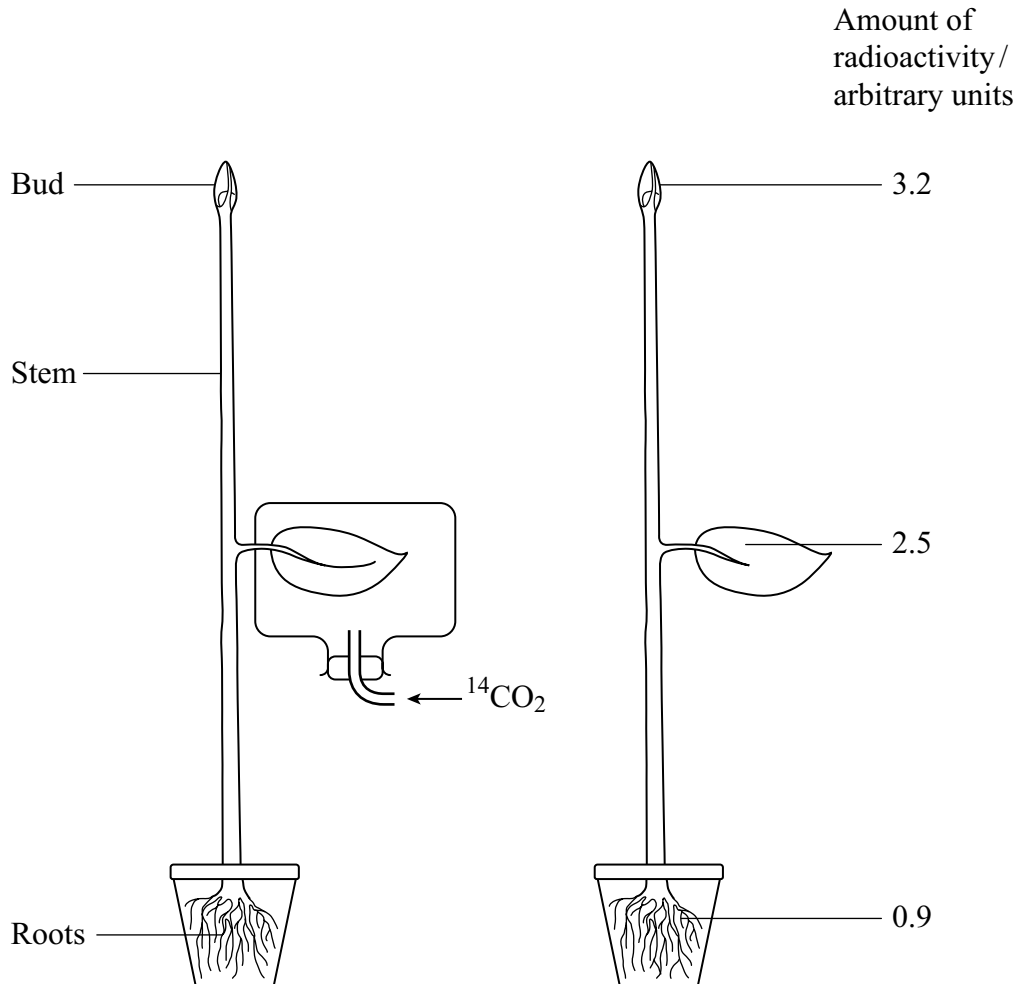

Only the treated leaf is shown.

- (a) The radioactive carbon is transported as a carbohydrate in the stem. Name this carbohydrate.

.....  
(1 mark)



(b) (i) Suggest **one** explanation for the difference in the amount of radioactivity in the bud and the roots.

.....  
.....  
.....  
.....

*(2 marks)*

(ii) Suggest why some radioactivity remains in the leaf.

.....  
.....

*(1 mark)*

(c) Describe how a ringing experiment could be carried out to determine which tissue transports the substances containing the radioactive carbon.

.....  
.....  
.....  
.....  
.....  
.....

*(3 marks)*

7
---

**There are no questions printed on this page**

5 (a) Pyruvate is formed in the breakdown of glucose during respiration. When there is sufficient oxygen, this pyruvate is fully broken down. Name **two** substances formed from the pyruvate.

1 .....

2 .....

(1 mark)

(b) (i) If there is a shortage of oxygen in muscle cells during exercise, some pyruvate is converted into lactate. Explain why muscles become fatigued when insufficient oxygen is available.

.....  
.....  
.....  
.....

(2 marks)

(ii) Some of the lactate is oxidised to pyruvate by muscles when they are well-supplied with oxygen. Suggest an advantage of the lactate being oxidised in the muscles.

.....  
.....  
.....  
.....

(2 marks)

**Turn over for the next question**

5
---

- 6 The chart shows the change in the speed of flow and pressure of blood from the start of the aorta into the capillaries.

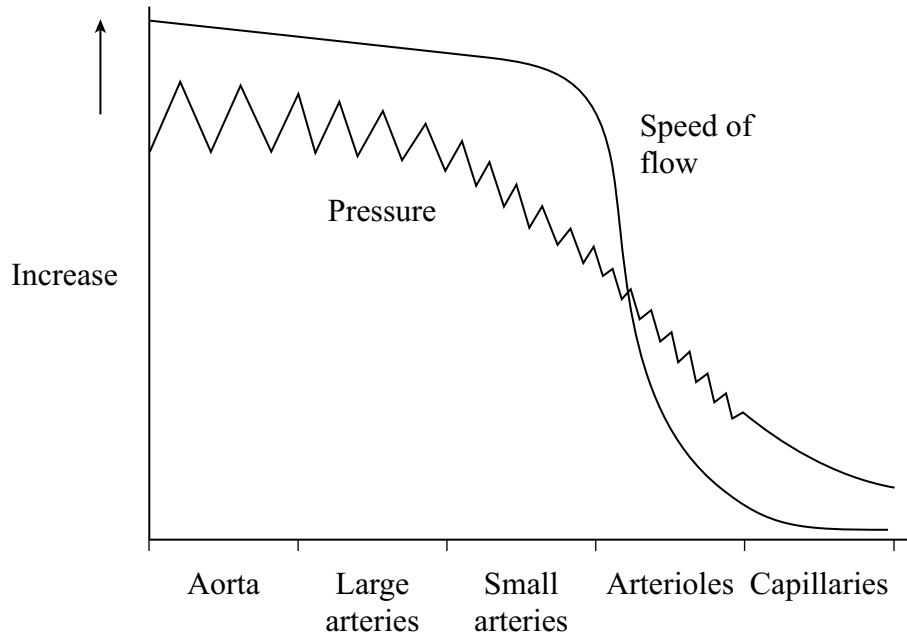

- (a) Describe and explain the changes in the speed of flow of the blood shown in the chart.

.....

.....

.....

.....

(2 marks)

(b) Explain how the structure of the arteries reduces fluctuations in pressure.

.....  
.....  
.....  
.....

*(2 marks)*

(c) Explain how the structure of capillaries is related to their function.

.....  
.....  
.....  
.....

*(2 marks)*

(d) In one cardiac cycle, the volume of blood flowing out of the heart along the pulmonary artery is the same as the volume of blood returning along the pulmonary vein. Explain why the volumes are the same although the speed of flow in the artery is greater than in the vein.

.....  
.....

*(1 mark)*

**Turn over for the next question**

7
---

7 The graph shows the oxygen haemoglobin dissociation curves for three species of fish.

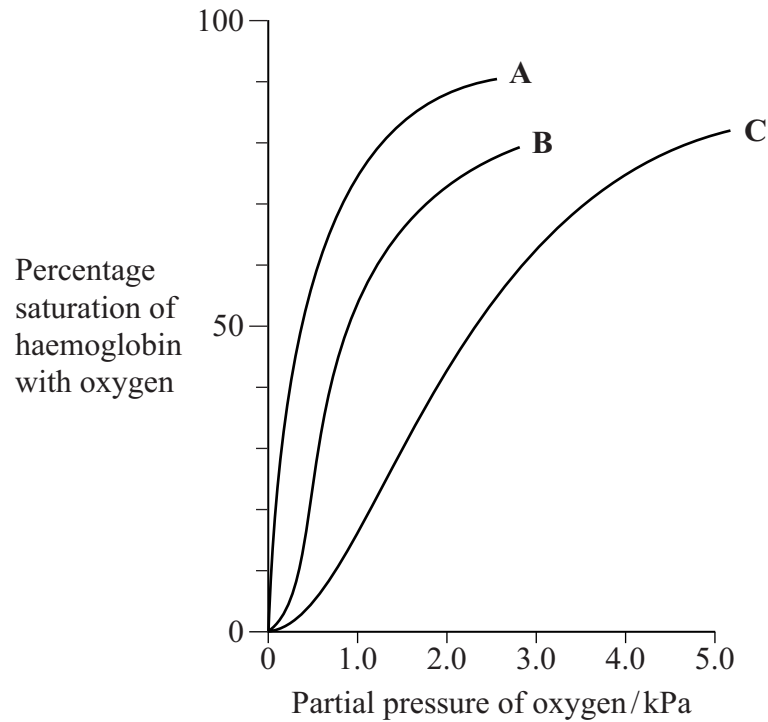

- (a) Species A lives in water containing a low partial pressure of oxygen. Species C lives in water with a high partial pressure of oxygen. The oxygen haemoglobin dissociation curve for species A is to the left of the curve for species C. Explain the advantage to species A of having haemoglobin with a curve in this position.

.....

.....

.....

.....

.....

.....

.....

(3 marks)

(b) Species **A** and **B** live in the same place but **B** is more active. Suggest an advantage to **B** of having an oxygen haemoglobin dissociation curve to the right of that for **A**.

.....

.....

.....

.....

.....

.....

(2 marks)

<b>5</b>

**Turn over for the next question**

Answer **Question 8** in continuous prose.  
Quality of Written Communication will be assessed in these answers.

**8** (a) Explain how a rise in blood pressure results in a decrease in the rate of heartbeat.

.....

.....

.....

.....

.....

.....

.....

.....

.....

.....

.....

.....

.....

.....

.....

.....

.....

.....

.....

.....

.....

.....

*(6 marks)*

(b) Some drugs inhibit the transmission of nerve impulses to the heart. Explain how these drugs reduce high blood pressure.

.....

.....

.....

.....

.....

.....

.....

.....

.....

.....

.....

.....

.....

.....

.....

.....

.....

.....

.....

.....

.....

*(2 marks)*

**END OF QUESTIONS**

8