

Surname						Other Names					
Centre Number						Candidate Number					
Candidate Signature											

For Examiner's Use

General Certificate of Education
 June 2007
 Advanced Subsidiary Examination



APPLIED SCIENCE
Unit 5 Choosing and Using Materials

SC05

ASSESSMENT and
 QUALIFICATIONS
 ALLIANCE

Tuesday 5 June 2007 1.30 pm to 3.00 pm

<p>For this paper you must have:</p> <ul style="list-style-type: none"> • a pencil and a ruler • a calculator.

Time allowed: 1 hour 30 minutes

Instructions

- Use blue or black ink or ball-point pen.
- Fill in the boxes at the top of this page.
- Answer **all** questions.
- Answer the questions in the spaces provided.
- Do all rough work in this book. Cross through any work you do not want to be marked.
- Show the working of your calculations.
- Pages 17 and 18 are perforated. Detach this sheet and use the information to answer Question 5.

Information

- The maximum mark for this paper is 80.
- The marks for questions are shown in brackets.
- You are expected to use a calculator where appropriate.

For Examiner's Use			
Question	Mark	Question	Mark
1		5	
2		6	
3		7	
4			
Total (Column 1) →			
Total (Column 2) →			
TOTAL			
Examiner's Initials			

Answer **all** questions in the spaces provided.

1 Architects who design buildings use a variety of materials.

- (a) In the table below, draw a line from each material to a correct description of its properties. Then fill in the empty boxes to suggest **one** possible use of each material in a building.

The properties and uses of one material have been completed for you.

Properties	Material	Suggested use
High compressive strength and easily made on site	Aluminium	
Good electrical conductor, fairly low density and will not rust	Concrete	
Tough, low density and a good electrical insulator	Glass	
High tensile strength but corrodes easily	PVC	Window frames
High tensile strength but brittle and cracks easily	Steel	

(4 marks)

- (b) The diagram shows a method for constructing a concrete arch. The timber beams and plywood are removed when the concrete has set.

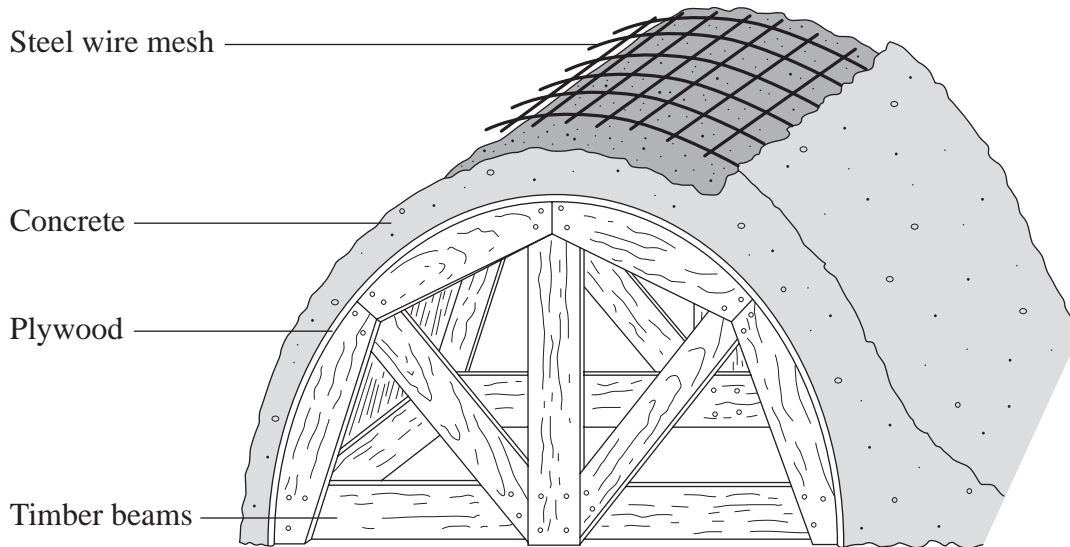

- (i) Why is the steel wire mesh necessary?

.....
.....
(1 mark)

- (ii) Why is plywood, rather than solid wood, used to make the curved wooden support?

.....
(1 mark)

Question 1 continues on the next page

- (c) The diagram shows the main floor and the balcony of a building under construction.

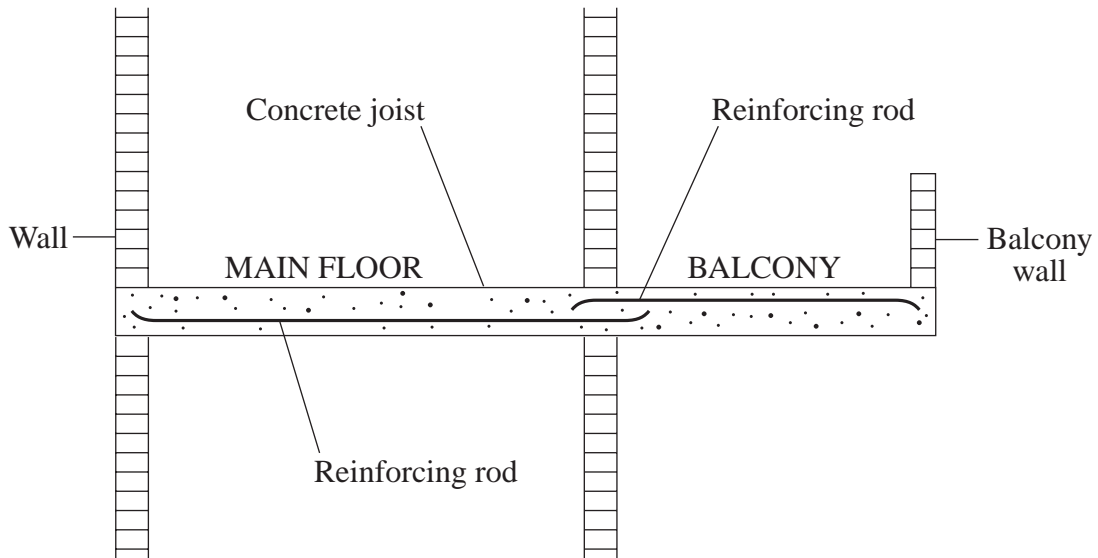

- (i) On the diagram, use an arrow labelled **C** to mark part of the main floor which is in compression. *(1 mark)*
- (ii) Why is the reinforcing rod in the balcony set in the top of the concrete but in the main floor it is set in the bottom of the concrete?
-
-
- (1 mark)*
- (iii) Instead of concrete, wooden joists are often used to support floors. Suggest **one** advantage and **one** disadvantage of using a wooden joist instead of a concrete joist.

Advantage

.....

Disadvantage

.....

(2 marks)

- (d) The spacing needed between the wooden joists supporting a floor depends on their length and cross-sectional area, this is shown in the table.

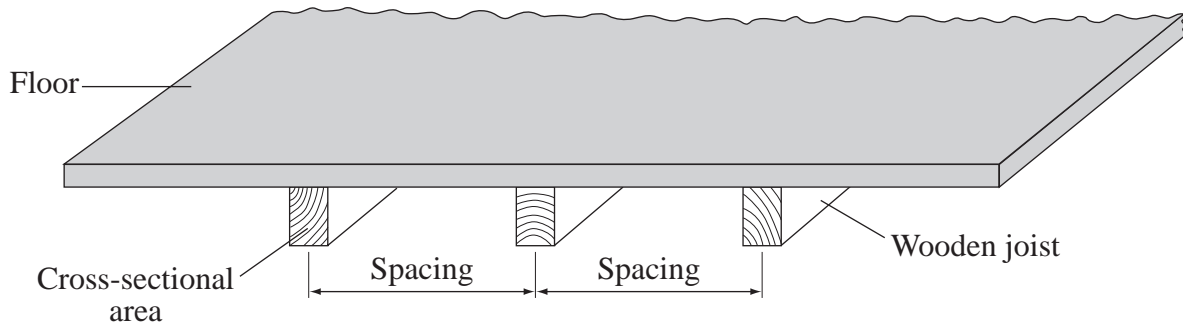

Length of joist	Cross-sectional area needed		
	400 mm spacing	500 mm spacing	600 mm spacing
2 m	3000 mm ²	3500 mm ²	4000 mm ²
3 m	4000 mm ²	4500 mm ²	5000 mm ²
4 m	5000 mm ²	6000 mm ²	7000 mm ²

- (i) Describe a simple relationship between the length of the joist and the cross-sectional area needed for the joists.

.....

 (1 mark)

- (ii) For the same load, the cross-sectional area of the joists must be greater if they are spaced further apart. Explain this using the idea of stress.

.....

 (2 marks)

2 A wire cable for a crane needs to have the correct stiffness. It must be made from a ductile material, but must have enough tensile strength to be able to support the required load.

(a) Define

(i) *stiffness*

.....
(1 mark)

(ii) *ductile*

.....
(1 mark)

(iii) *tensile strength*

.....
(1 mark)

(b) The diagram shows a graph of stress against strain for the wire cable.

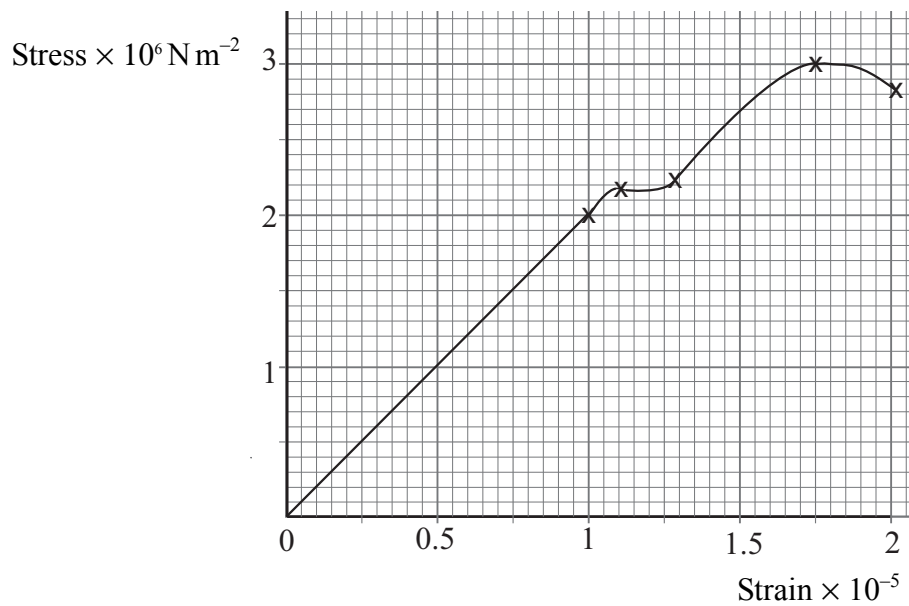

Write down the definition of

(i) *stress*

.....

(1 mark)

(ii) *strain*

.....

(1 mark)

(c) On the graph on **page 6**, label

(i) with a letter **E**, one point at which the wire is undergoing elastic deformation,
(1 mark)

(ii) with a letter **P**, one point at which the wire is undergoing plastic deformation,
(1 mark)

(iii) with a letter **Y**, the yield point.
(1 mark)

(d) Give the meaning of the terms

(i) *elastic deformation*

.....

(1 mark)

(ii) *plastic deformation*

.....

(1 mark)

(iii) *yield point*.

.....

(1 mark)

(e) Using data from the graph on **page 6**, calculate the Young modulus when the stress is $1 \times 10^6 \text{ N m}^{-2}$.

.....

.....

.....

(3 marks)

- (f) The four graphs below show stress plotted against strain for four different materials, **A**, **B**, **C** and **D**.

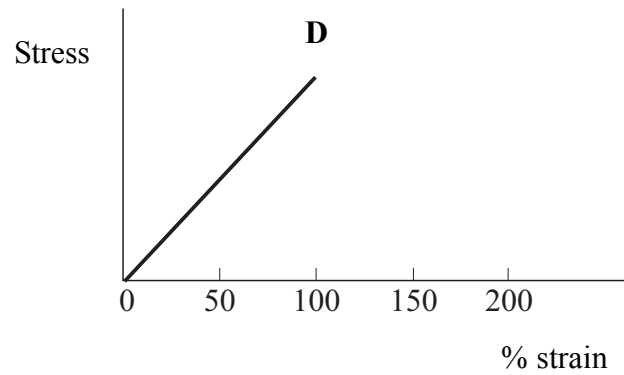
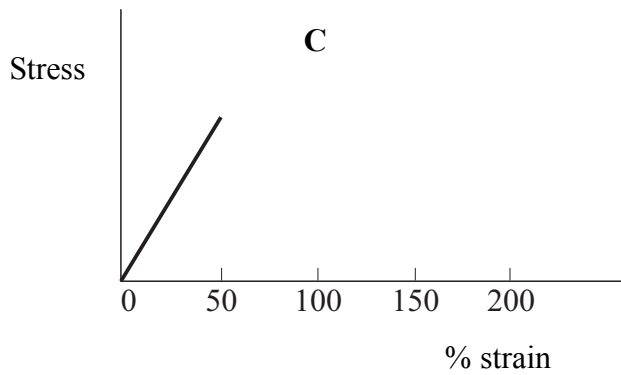
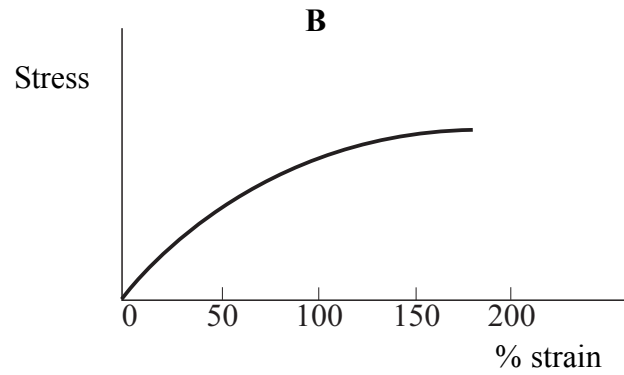
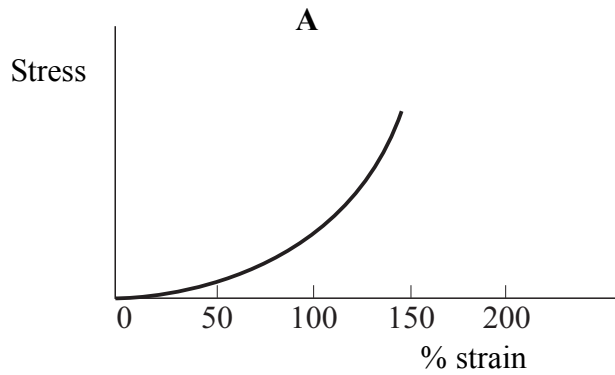

- (i) Which material, **A**, **B**, **C**, or **D**, is easy to stretch to start with and then gets more difficult?

Material..... (1 mark)

- (ii) Which material, **A**, **B**, **C**, or **D**, will double its original length when stretched and then break?

Material..... (1 mark)

- (g) Searle’s apparatus can be used to measure the stiffness of a wire. The diagram below shows this apparatus.

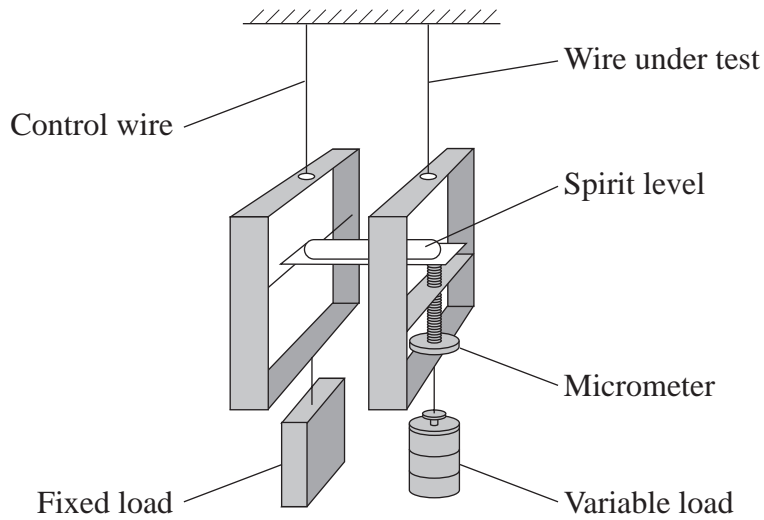

Describe how you could use this apparatus to measure the stiffness of a wire.

.....

.....

.....

.....

.....

.....

.....

.....

.....

.....

.....

.....

.....

.....

.....

.....

.....

.....

.....

.....

.....

.....

.....

(5 marks)

- 3 The diagram shows parts of a boat.
Part X shows a section through the hull.
Part Y shows part of the propeller and shaft.

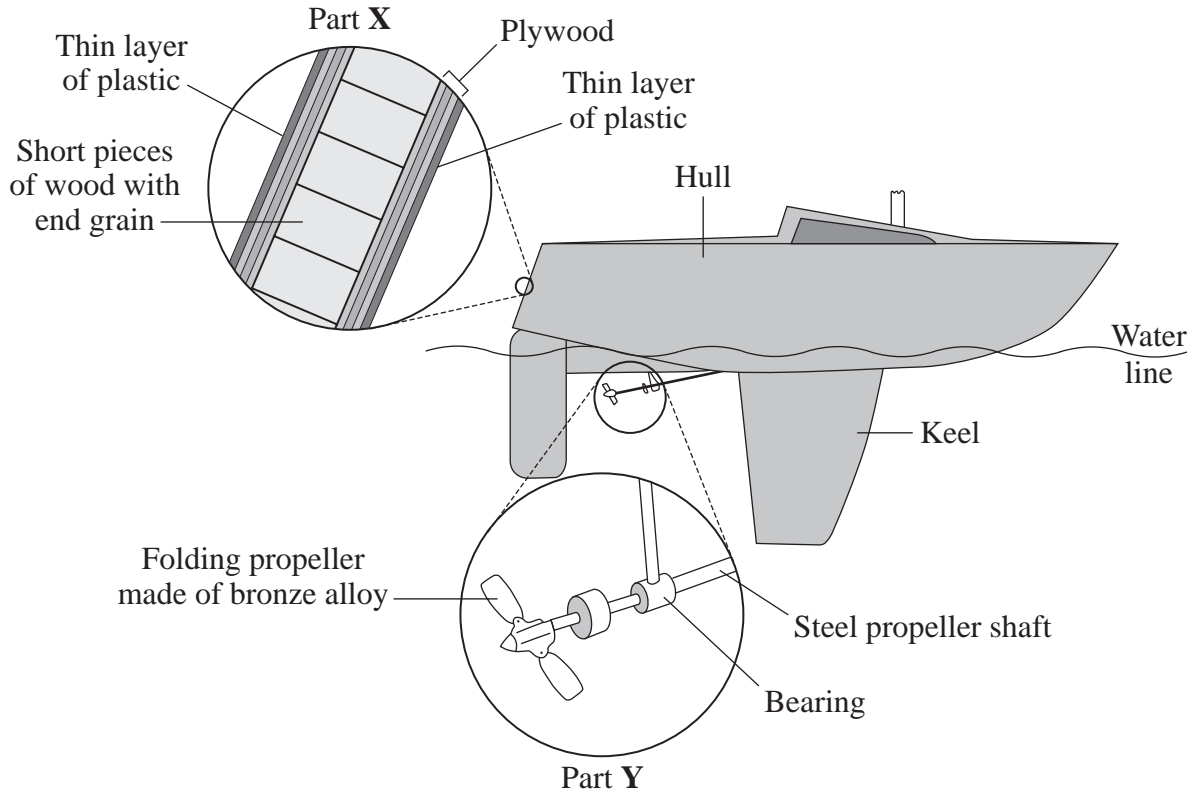

(a) The hull is made from a composite material.

(i) Explain what is meant by the term *composite material*.

.....
.....

(1 mark)

(ii) In each case, suggest **one** advantage of making the hull from wood, rather than steel,

.....
.....

a composite material, rather than solid wood.

.....
.....

(2 marks)

(iii) Suggest **one** advantage of coating the hull with a thin layer of plastic.

.....
(1 mark)

(b) Steel and bronze are both alloys.

(i) What is the meaning of the term *alloy*?

.....
.....
(1 mark)

(ii) Suggest **one** advantage of using a bronze alloy rather than pure copper for the propeller.

.....
.....
(1 mark)

Question 3 continues on the next page

- (c) Some alloys are called 'shape memory alloys'. These can undergo a solid-state phase change, resulting in a molecular rearrangement. One phase, which exists at low temperatures, is called Martensite. In one form, this is soft and easily deformed when a load is applied. When the deformed Martensite is heated it changes phase to become Austenite. This has the same size and shape as the original undeformed Martensite. On cooling, the Austenite reverts to undeformed Martensite, and the whole process can be repeated.

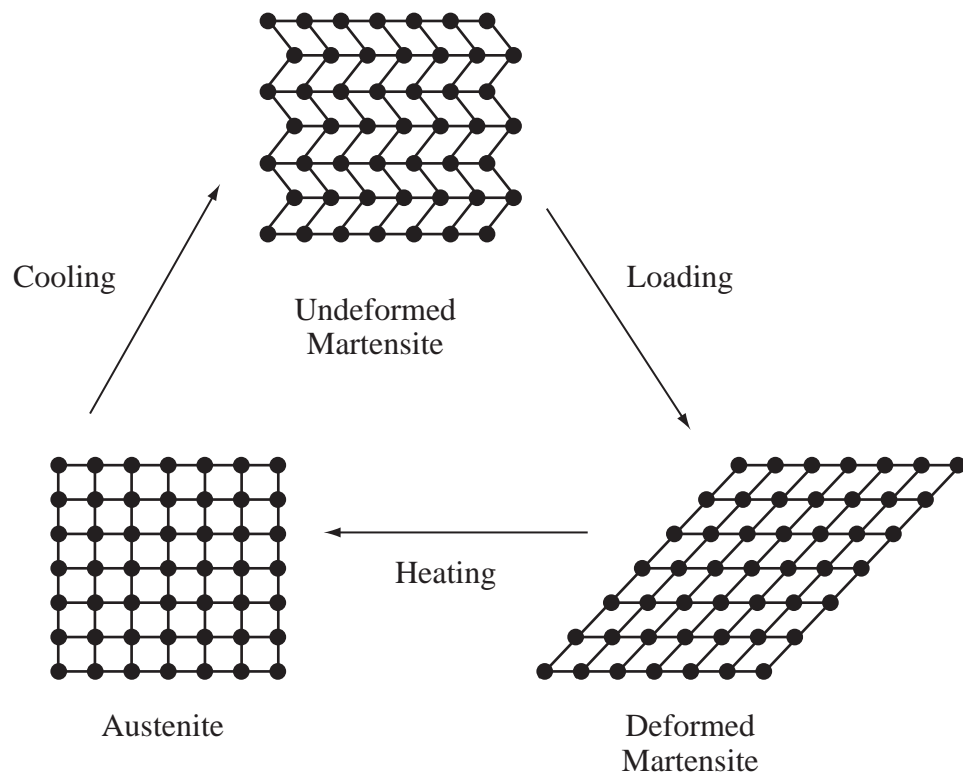

- (i) What word describes the arrangement of the molecules in Austenite?

Draw a ring around the correct answer.

amorphous

cubic

polymeric

(1 mark)

- (ii) Energy is required to change from Martensite to Austenite. Where does this energy come from?

.....
(1 mark)

- (iii) Which **one** of the following would be a suitable application for the use of a shape memory alloy?

Tick the box beside the correct answer.

Bridge girders

Hot water tanks

Space shuttle nose cones

Spectacle frames

(1 mark)

9

Turn over for the next question

4 The diagram shows the structure of two different types of window.

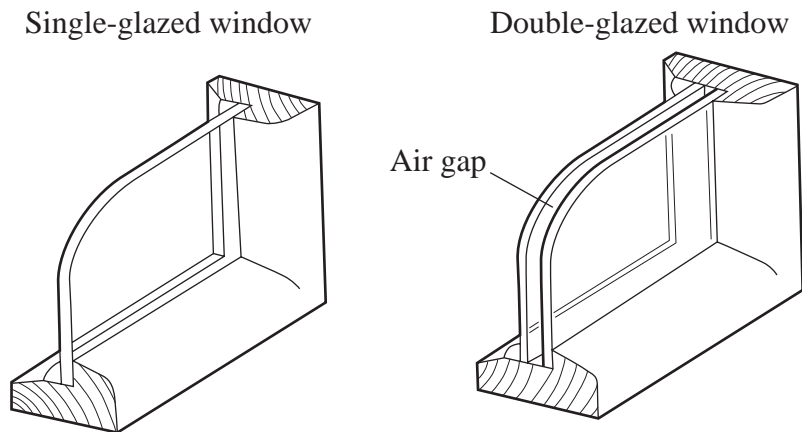

Double-glazing is a way of insulating houses against heat loss. The diagram below is taken from a brochure from a double-glazing company.

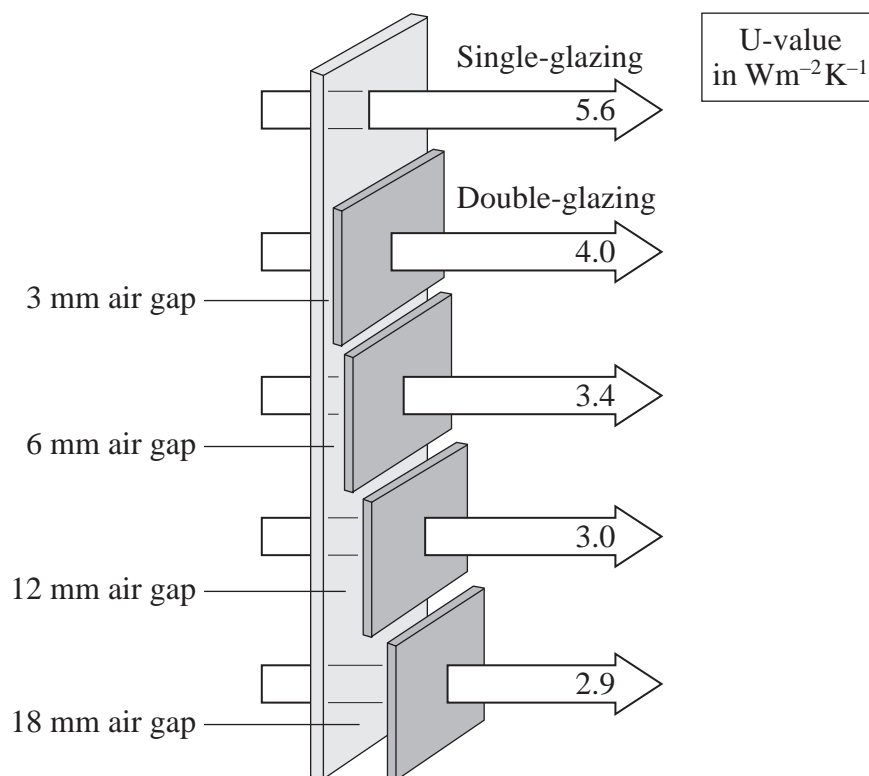

These figures are based on a glass thickness of 4 mm

- (a) (i) On the grid below draw a graph of the width of the air gap plotted against the U-value as quoted in the double-glazing company brochure.

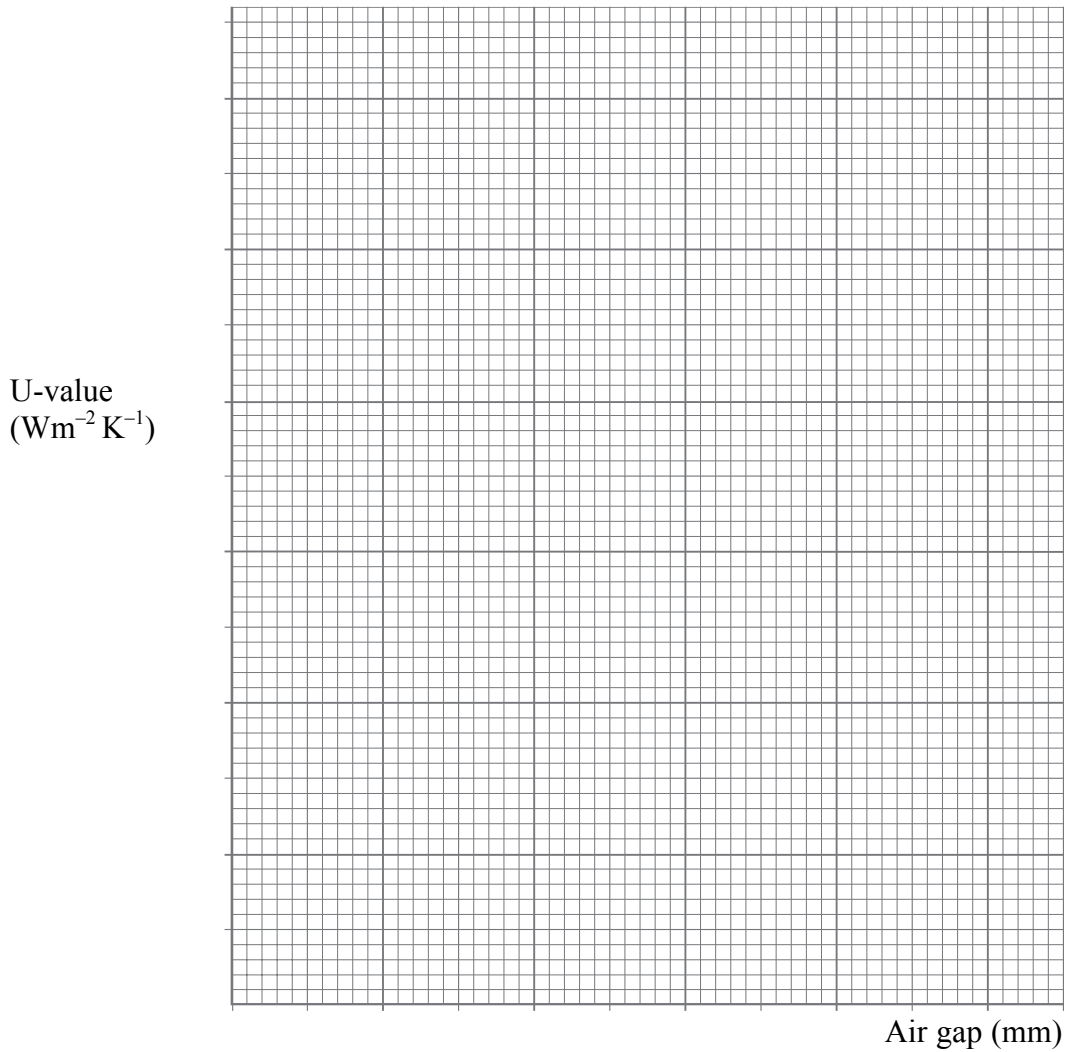

(3 marks)

- (ii) Use your graph to describe the effect on the U-value of increasing the width of the air gap.

.....

.....
(2 marks)

Question 4 continues on the next page

(b) The U-value is a measure of the rate at which heat is lost from a particular window. It is measured in watts per square metre per Kelvin.

(i) Using thicker glass in the single-glazed window would increase the U-value. What is the reason for this?

.....

.....

(1 mark)

(ii) Other than the thickness of the glass, write down **one** factor that will affect the rate at which heat is lost from a double-glazed window.

.....

(1 mark)

(c) Some window frames are made from plastics such as PVC rather than from wood.

Suggest **one** advantage and **one** disadvantage of using PVC rather than wood for window frames.

Advantage

.....

Disadvantage

.....

(2 marks)

Read this article about polymers and use the information to answer Question 5.

Polymers

Polymers consist of many monomers joined together. One of the simplest polymers is poly(ethene), commonly called polythene.

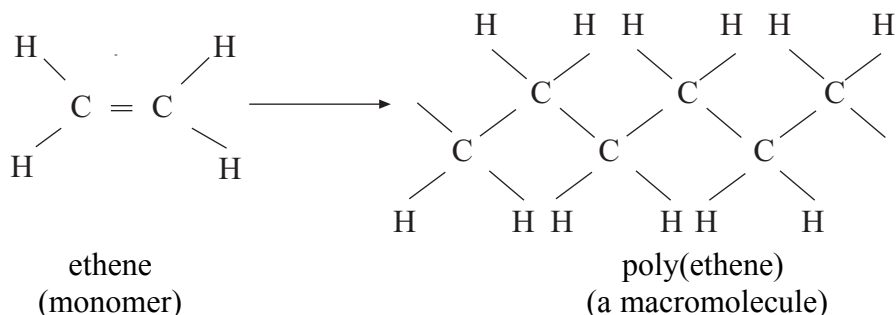

The formula for poly(ethene) is written as: $-(\text{CH}_2-\text{CH}_2)_n-$
In this case n ranges from 10 000 to 100 000.

The table below shows some common polymers.

Name	Formula	Monomer	Properties	Uses
High density Polythene (HDPE)	$-(\text{CH}_2-\text{CH}_2)_n-$	Ethene $\text{CH}_2=\text{CH}_2$	Rigid, translucent solid	Bottles, electrical insulation
Low density Polythene (LDPE)	$-(\text{CH}_2-\text{CH}_2)_n-$	Ethene $\text{CH}_2=\text{CH}_2$		
Polyvinyl chloride (PVC)	$-(\text{CH}_2-\text{CHCl})_n-$	Vinyl chloride	Strong, rigid solid	Pipes, flooring
cis-polyisoprene (natural rubber)	$-\text{[CH}_2-\text{C}(\text{CH}_3)=\text{CH}-\text{H}_2\text{]}_n-$	$\text{CH}_2=\text{C}(\text{CH}_3)\text{CH}=\text{CH}_2$	Soft, sticky liquid	Needs treatment before practical use

LDPE is composed of short, branched chains that form a mainly amorphous mass. HDPE is composed of longer, unbranched chains which pack together to form a more crystalline solid. This makes it harder, stronger, more dense and less easily deformed than LDPE. Mechanical properties such as ductility and tensile strength usually increase with increasing chain length.

Natural rubber is composed of a completely amorphous polymer. If the chains of rubber molecules are cross-linked with sulphur atoms, the rubber becomes harder and less sticky. This process is called vulcanisation.



Unstretched rubber

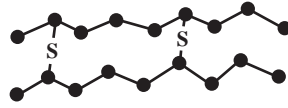

Stretched rubber

The graph below shows the behaviour of a piece of rubber when stretched.

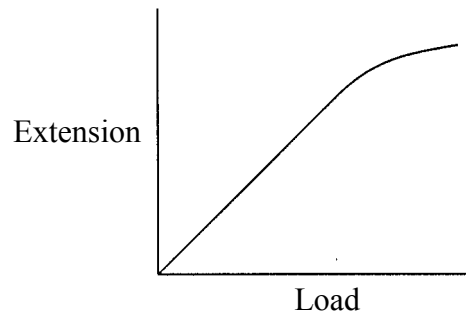

Most polymers are very good electrical insulators. However, polypyrroles, another type of polymer, can have an electrical conductivity almost as high as copper. By coating other polymers with polypyrroles a material can be made that combines the properties of metals and polymers.

5 Use the information from the article on **page 17** and **page 18** and your own knowledge to answer the following questions.

(a) (i) Other than low density, write down **one** property of LDPE.

.....
(1 mark)

(ii) State **one** use of LDPE.

.....
(1 mark)

(iii) Write down the formula of the monomer used to make PVC.

.....
(1 mark)

(iv) Name the monomer used to make natural rubber.

.....
(1 mark)

(b) (i) Name the type of bond that joins the two carbon atoms in ethene.

.....
(2 marks)

(ii) Explain how this bond makes the process of polymerisation possible.

.....
.....
(1 mark)

Question 5 continues on the next page

(c) The diagram shows the structures of two types of polythene.

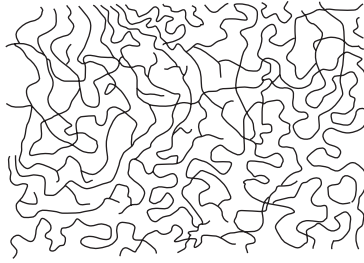

Sample A

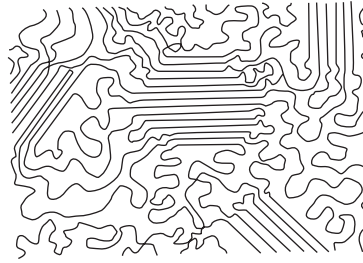

Sample B

Which sample shows HDPE?
Explain the reason for your choice.

Sample

Reason
.....
(1 mark)

(d) Explain how the process of vulcanisation makes natural rubber harder and less sticky.

.....
.....
(1 mark)

(e) From **page 18**, use the diagrams of unstretched and stretched rubber to explain the shape of the graph.

.....
.....
.....
.....
(2 marks)

(f) Suggest **one** advantage of using an electrically conducting polymer rather than a metal to carry an electric current.

.....
.....
(1 mark)

Turn over for the next question

6 The table shows the thermal expansivity of some metals.

Metal	Linear thermal expansivity (K^{-1})
Brass	0.000019
Copper	0.000017
Invar	0.000002
Iron	0.000012
Nickel	0.000013
Platinum	0.000009

These figures can be used to calculate how much a metal will expand when heated, using the formula:

$$\text{expansion} = \text{original length} \times \text{thermal expansivity} \times \text{temperature change.}$$

- (a) If all these metals had their temperature raised by 100 K, which metal would expand the least?

.....
(1 mark)

- (b) A copper bar, 30 cm long, is heated to raise its temperature by 100 K.
By how much does its length increase?
(Remember to include the correct units in your answer.)

.....
.....
.....
(2 marks)

(c) The diagram shows a thermostat for a gas oven.

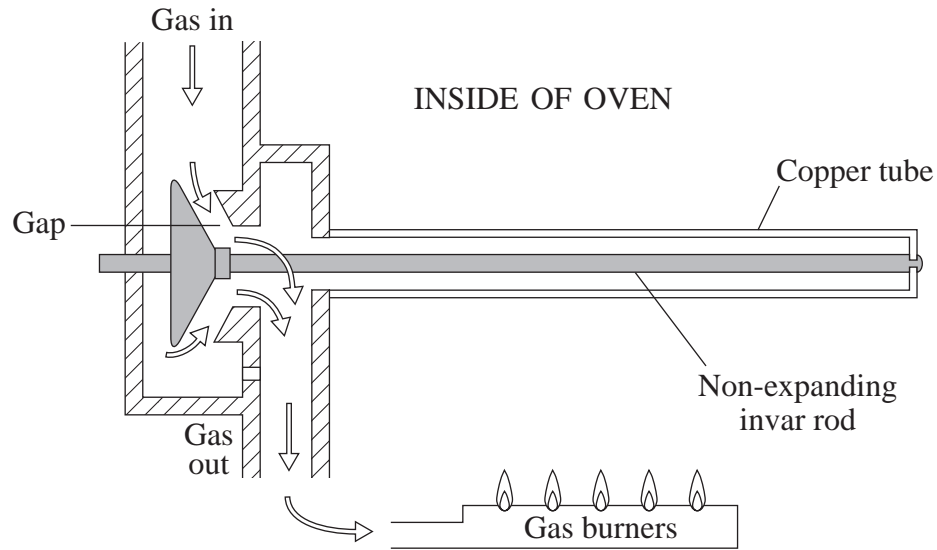

Explain how the different expansivities of copper and invar enable this device to keep the temperature of the oven steady.

.....

.....

.....

.....

(2 marks)

5

Turn over for the next question

7 The diagram shows two types of electrical cable used in a car.

Type A is used to carry a current at very high voltage to the spark plugs.

Type B is used to carry a very large current from the battery to the starter motor.

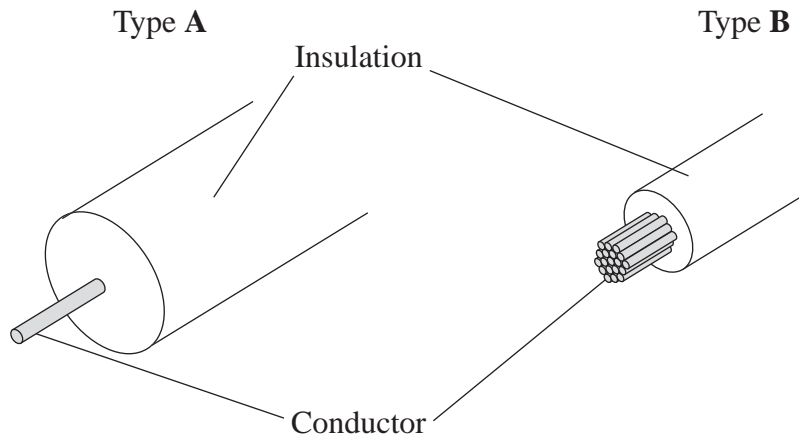

(a) Describe and explain the differences between the two types of cable.

.....

.....

.....

.....

(3 marks)

(b) The cable carrying the current to the starter motor has a copper core. The manufacturer claims that the electrical conductivity of the copper is $5.8 \times 10^7 \Omega^{-1} \text{ m}^{-1}$.

$$\text{Electrical conductivity} = \frac{\text{length} \times \text{current}}{\text{voltage} \times \text{cross-sectional area}}$$

You are given a sample of this cable, but do not have a conductivity meter.

Explain how you could carry out an investigation in the laboratory in order to be able to calculate the conductivity.

You should include what measurements you would need to make, and what instruments you would use to make these measurements. You should also include how you would use these measurements to calculate the conductivity.

There are no questions printed on this page

There are no questions printed on this page

There are no questions printed on this page